

8. TORCH OPERATION

Torch Parts Selection

The application will determine which torch parts must be used. Refer to the cut charts for the proper torch parts to install for a selected application.



CAUTION

Do not interchange parts. Make sure all torch parts correspond with the plasma and shield gases in use for the application.

Pre-Setting Power Supply Controls

Set the Power Supply controls prior to operating the system as described in the power supply Operating Manual. Refer to the cutting charts for the proper cutting parameters for the application.

Recommended Cutting Speeds

Cutting speed depends on material and thickness. The following factors may affect system performance:

- Torch parts wear; gas quality and mass flow / pressure; operator experience; torch standoff height; proper work cable connection; alloying contents of material; cutting table capabilities & accuracy.

NOTE

This information represents realistic expectations using recommended practices and well-maintained systems. Actual speeds may vary from those shown in the charts depending on the alloy content of the selected material. Voltage ratings may vary depending on the CNC, cutting table, or height controller.

For complete cutting speed chart data refer to the following pages.

Consumables Notes

Always assemble the consumable parts properly. Improper assembly may damage the parts or the torch head. Ensure that parts are seated together correctly.

Always check the shield gas distributor for charring when changing parts. Do not use the distributor if it is charred. Replace the shield gas distributor regularly to ensure proper performance.

Operational Notes

Always purge the torch after changing consumables or if the power supply has been shut off. The power supply's built-in purge function may not be enough to properly purge the torch. Manually flow gas with the 'Test Cut Flow' and 'Test Pre-Flow' functions to help remove any remaining coolant from the lines.

Slightly increasing the preflow pressure may increase piercing ability on thicker materials. However, increasing the preflow pressure too much may affect plasma starting reliability (misfiring).

Decreasing preflow pressure may improve piloting. Preflow pressure can be reduced without affecting cut performance as long as the pilot arc still transfers to the plate well. Decreasing preflow pressure too much will affect the ability to transfer the arc to the plate and may cause damage to the tip.

Notes on Chart Measurements

Pressure measurements in the charts are in psi(g), not psi(a). 0 psi(g) = 14.7 psi(a) (1 atmosphere).

Ball settings are at the center of the gauge ball.

Ohmic Sensing

Ohmic sensing is not recommended with water shield. Water on the plate interferes electrically with the ohmic sensing circuit.

Direction of Cut

The plasma gas stream swirls as it leaves the torch to maintain a stable arc column. This swirl effect results in one side of a cut being more square than the other. Viewed along the direction of travel, the right side of the cut is more square than the left.

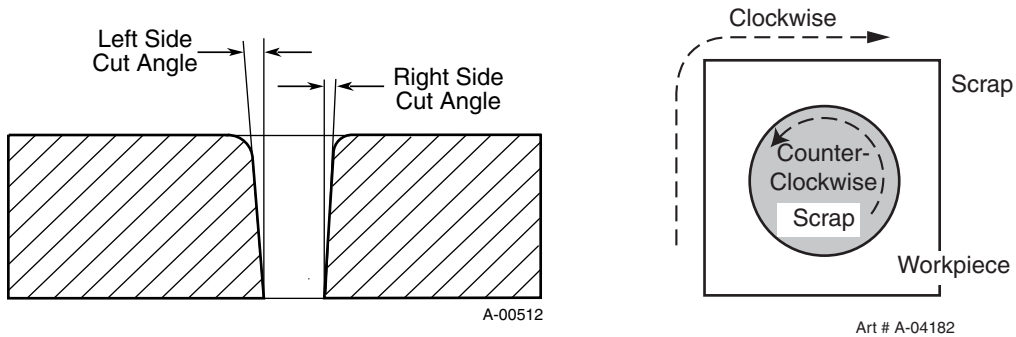

Side Characteristics Of Cut

To make a square - edged cut along an inside diameter of a circle, move the torch counterclockwise around the circle. To keep the square edge along an outside diameter cut, move the torch in a clockwise direction.

Underwater Cutting

Cutting on a water table either underwater or with the water touching the plate or with a water muffler system is not recommended. If a water table is used the water level must be a minimum of 4 inches / 100 mm from the bottom of the plate. Failure to follow this recommendation could result in poor cut quality and short consumable parts life.

Mild Steel,

55A

O₂ Plasma / Air Shield

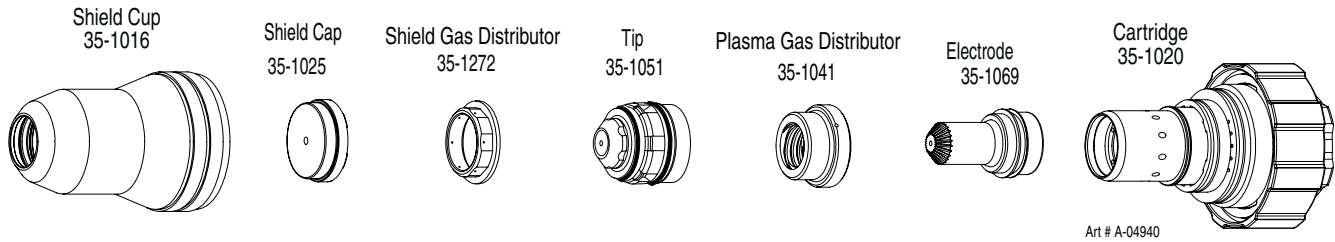

55A Mild Steel (O ₂ /Air)										
Material Thickness			Cut Flow Pressures		Arc Voltage	Torch Working Height	Travel Speed	Initial Piercing Height	Pierce Delay	Kerf Width @ Rec. Speed
			Plasma (O ₂)	Shield (Air)						
(ga)	(in)	inch	(PSI)	(PSI)	Volts	(in) ±0.005	(ipm)	(in)	(sec)	(in)
21		0.033	70	20	120	0.125	600	0.200	0.0	0.073
16		0.060	70	20	120	0.125	400	0.200	0.0	0.071
10		0.135	80	20	126	0.125	180	0.200	0.2	0.083
	3/16	0.188	80	20	127	0.125	120	0.200	0.2	0.081
	1/4	0.250	80	20	128	0.125	85	0.200	0.3	0.086

55A Mild Steel (O ₂ /Air)									
Material Thickness		Cut Flow Pressures		Arc Voltage	Torch Working Height	Travel Speed	Initial Piercing Height	Pierce Delay	Kerf Width @ Rec. Speed
		Plasma (O ₂)	Shield (Air)						
(mm)		(Bar)	(Bar)	Volts	(mm) ±0.1	(mm/min)	(mm)	(sec)	(mm)
1		4.8	1.4	120	3.2	14040	5.1	0.0	1.8
2		4.8	1.4	121	3.2	8760	5.1	0.0	1.9
3		5.5	1.4	125	3.2	5830	5.1	0.2	2.0
4		5.5	1.4	126	3.2	3930	5.1	0.2	2.1
5		5.5	1.4	127	3.2	2920	5.1	0.2	2.1
6		5.5	1.4	128	3.2	2360	5.1	0.3	2.2

Mild Steel

55A

Air Plasma / Air Shield

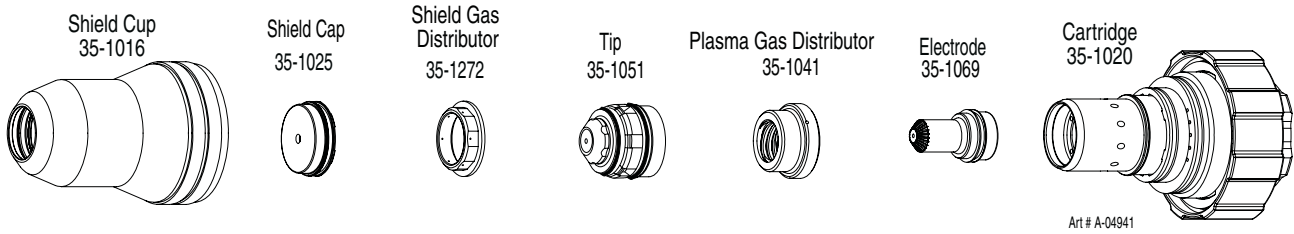

55A Mild Steel (Air/Air)										
Material Thickness			Cut Flow Pressures		Arc Voltage	Torch Working Height	Travel Speed	Initial Piercing Height	Pierce Delay	Kerf Width @ Rec. Speed
			Plasma (Air)	Shield (Air)						
(ga)	(in)	inch	(PSI)	(PSI)	Volts	(in) ±0.005	(ipm)	(in)	(sec)	(in)
21		0.033	70	20	152	0.188	500	0.200	0.1	0.079
16		0.060	70	20	154	0.188	300	0.200	0.1	0.086
10		0.135	92	80	166	0.188	190	0.200	0.2	0.079
	3/16	0.188	92	80	166	0.188	130	0.250	0.3	0.089
	1/4	0.250	92	80	170	0.188	95	0.250	0.3	0.090

Material Thickness		Cut Flow Pressures		Arc Voltage	Torch Working Height	Travel Speed	Initial Piercing Height	Pierce Delay	Kerf Width @ Rec. Speed
		Plasma (Air)	Shield (Air)						
(mm)		(Bar)	(Bar)	Volts	(mm) ±0.1	(mm/min)	(mm)	(sec)	(mm)
1		4.8	1.4	152	4.8	11500	5.1	0.1	2.0
2		4.8	1.4	157	4.8	6920	5.1	0.1	2.1
3		6.3	5.5	163	4.8	5460	5.1	0.2	2.0
4		6.3	5.5	166	4.8	4180	5.6	0.2	2.1
5		6.3	5.5	167	4.8	3180	6.4	0.3	2.3
6		6.3	5.5	169	4.8	2610	6.4	0.3	2.3

Mild Steel

100A

O₂ Plasma / Air Shield

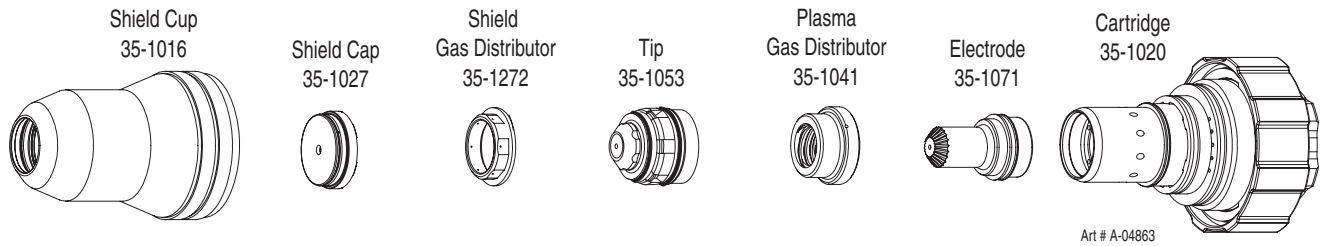

100A Mild Steel (O ₂ /Air)										
Material Thickness			Cut Flow Pressures		Arc Voltage	Torch Working Height	Travel Speed	Initial Piercing Height	Pierce Delay	Kerf Width @ Rec. Speed
			Plasma (O ₂)	Shield (Air)						
(ga)	(in)	inch	(PSI)	(PSI)	Volts	(in) ±0.005	(ipm)	(in)	(sec)	(in)
16		0.060	94	49	127	0.110	500	0.250	0.1	0.071
10		0.135	94	49	134	0.110	240	0.250	0.2	0.081
	3/16	0.188	94	49	128	0.120	185	0.250	0.3	0.073
	1/4	0.250	94	49	130	0.120	130	0.300	0.3	0.095
	3/8	0.375	94	49	138	0.130	80	0.300	0.3	0.113
	1/2	0.500	94	49	138	0.140	57	0.300	0.3	0.113
	5/8	0.625	94	49	144	0.140	45	0.350	0.5	0.111
	3/4	0.750	94	49	150	0.150	25	0.350	0.6	0.138
	1	1.000	94	49	164	0.200	10	Edge Start		0.140

Material Thickness		Cut Flow Pressures		Arc Voltage	Torch Working Height	Travel Speed	Initial Piercing Height	Pierce Delay	Kerf Width @ Rec. Speed
		Plasma (O ₂)	Shield (Air)						
(mm)	(mm)	(Bar)	(Bar)	Volts	(mm) ±0.1	(mm/min)	(mm)	(sec)	(mm)
2		6.5	3.4	129	2.8	11050	6.4	0.1	1.9
3		6.5	3.4	132	2.8	7580	6.4	0.2	2.0
4		6.5	3.4	131	2.9	5500	6.4	0.2	2.0
5		6.5	3.4	128	3.1	4500	6.5	0.3	1.9
6		6.5	3.4	130	3.1	3610	7.3	0.3	2.3
8		6.5	3.4	134	3.2	2640	7.6	0.3	2.7
10		6.5	3.4	138	3.3	1950	7.6	0.3	2.9
12		6.5	3.4	138	3.5	1580	7.6	0.3	2.9
15		6.5	3.4	142	3.6	1230	8.5	0.4	2.8
20		6.5	3.4	152	4.0	580	9.5	0.6	3.5
25		6.5	3.4	163	5.0	280	Edge Start		3.6

Mild Steel

100A

Air Plasma / Air Shield

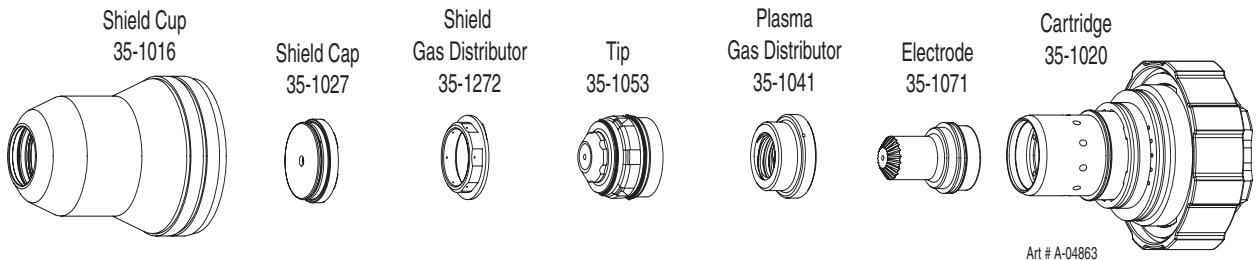

100A Mild Steel (Air/Air)										
Material Thickness			Cut Flow Pressures		Arc Voltage	Torch Working Height	Travel Speed	Initial Piercing Height	Pierce Delay	Kerf Width @ Rec. Speed
			Plasma (Air)	Shield (Air)						
(ga)	(in)	inch	(PSI)	(PSI)	Volts	(in) ±0.005	(ipm)	(in)	(sec)	(in)
16		0.060	90	45	149	0.110	600	0.250	0.1	0.072
10		0.135	90	45	145	0.110	300	0.250	0.2	0.065
	3/16	0.188	90	45	149	0.110	210	0.250	0.3	0.073
	1/4	0.250	90	45	152	0.120	150	0.300	0.3	0.078
	3/8	0.375	90	45	152	0.130	85	0.300	0.3	0.091
	1/2	0.500	90	45	159	0.140	75	0.300	0.3	0.095
	5/8	0.625	90	45	153	0.140	55	0.350	0.5	0.099
	3/4	0.750	90	45	163	0.150	30	0.350	0.6	0.120
	1	1.00	90	45	180	0.200	20	Edge Start		0.112

Material Thickness		Cut Flow Pressures		Arc Voltage	Torch Working Height	Travel Speed	Initial Piercing Height	Pierce Delay	Kerf Width @ Rec. Speed
		Plasma (Air)	Shield (Air)						
(mm)	(mm)	(Bar)	(Bar)	Volts	(mm) ±0.1	(mm/min)	(mm)	(sec)	(mm)
2		6.2	3.1	148	2.8	13340	6.4	0.1	1.8
3		6.2	3.1	146	2.8	9340	6.4	0.2	1.7
4		6.2	3.1	147	2.8	6650	6.4	0.2	1.7
5		6.2	3.1	149	2.8	5120	6.5	0.3	1.9
6		6.2	3.1	151	3.0	4150	7.3	0.3	2.0
8		6.2	3.1	152	3.2	2950	7.6	0.3	2.2
10		6.2	3.1	153	3.3	2120	7.6	0.3	2.3
12		6.2	3.1	157	3.5	1960	7.6	0.3	2.4
15		6.2	3.1	155	3.6	1540	8.5	0.4	2.5
20		6.2	3.1	166	4.0	720	9.5	0.6	3.0
25		6.2	3.1	179	5.0	520	Edge Start		2.9

Mild Steel

200A

Air Plasma / Air Shield

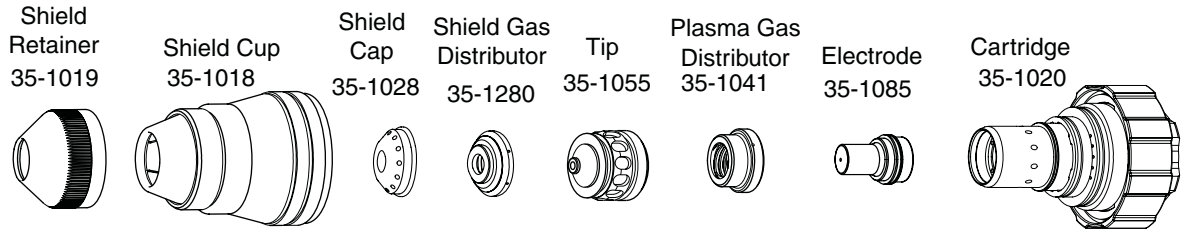

Art # A-06988

200A Mild Steel (Air/Air)										
Material Thickness			Cut Flow Pressures		Arc Voltage	Torch Working Height	Travel Speed	Initial Piercing Height	Pierce Delay	Kerf Width @ Rec. Speed
			Plasma (Air)	Shield (Air)						
(ga)	(in)	inch	(PSI)	(PSI)	Volts	(in) ±0.005	(ipm)	(in)	(sec)	(in)
	1/4	0.250	90	60	163	0.140	185	0.300	0	0.096
	3/8	0.375	90	60	160	0.140	130	0.300	0.1	0.131
	1/2	0.500	90	60	162	0.140	100	0.300	0.3	0.150
	5/8	0.625	90	60	164	0.140	75	0.300	0.4	0.158
	3/4	0.750	90	60	168	0.180	60	0.350	0.5	0.176
	1	1.000	90	60	177	0.200	35	0.500	1.5	0.189
	1-1/4	1.250	90	60	185	0.250	20	Edge Start		0.209
	1-1/2	1.500	90	60	189	0.250	15	Edge Start		0.225
	2	2.000	90	60	204	0.300	10	Edge Start		0.270

Material Thickness		Cut Flow Pressures		Arc Voltage	Torch Working Height	Travel Speed	Initial Piercing Height	Pierce Delay	Kerf Width @ Rec. Speed
		Plasma (Air)	Shield (Air)						
(mm)	(mm)	(Bar)	(Bar)	Volts	(mm) ±0.1	(mm/min)	(mm)	(sec)	(mm)
6		6.2	4.1	163	3.6	4700	7.6	0	2.4
8		6.2	4.1	161	3.6	3970	7.6	0.1	2.9
10		6.2	4.1	160	3.6	3190	7.6	0.1	3.4
12		6.2	4.1	162	3.6	2710	7.6	0.3	3.7
15		6.2	4.1	163	3.6	2080	7.6	0.4	4.0
20		6.2	4.1	169	4.6	1430	9.5	0.6	4.5
25		6.2	4.1	176	5.0	920	12.5	1.4	4.8
32		6.2	4.1	185	6.4	500	Edge Start		5.3
38		6.2	4.1	189	6.4	380	Edge Start		5.7
44		6.2	4.1	196	6.9	320	Edge Start		6.2
50		6.2	4.1	203	7.5	260	Edge Start		6.8

Mild Steel

200A

O₂ Plasma / Air Shield

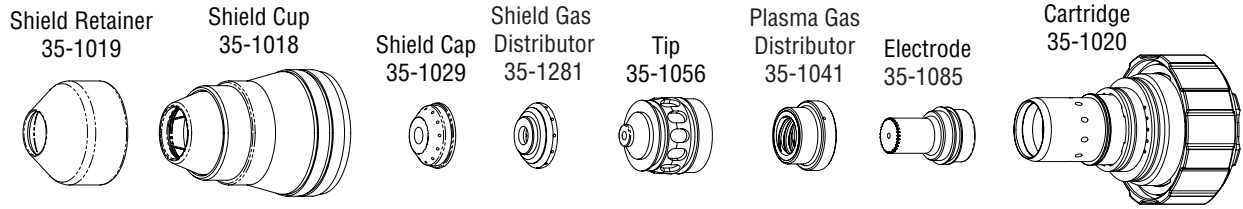

Art # A-07612

200A Mild Steel O ₂ /Air										
Material Thickness			Cut Flow		Arc Voltage	Torch Working Height	Travel Speed	Initial Piercing Height	Pierce Delay	Kerf Width @ Rec. Speed
			Plasma (O ₂)	Shield (Air)						
(ga)	(in)	inch	(PSI)	(PSI)	Volts	(in) ±0.005	(ipm)	(in)	(sec)	(in)
	1/4	0.250	90	58	154	0.140	190	0.300	0.1	0.153
	3/8	0.375	90	58	156	0.140	140	0.300	0.3	0.159
	1/2	0.500	90	58	158	0.140	100	0.350	0.4	0.168
	5/8	0.625	90	58	161	0.140	70	0.350	0.5	0.183
	3/4	0.750	90	58	168	0.160	60	0.400	0.6	0.192
	1	1.000	90	58	170	0.180	40	0.500	0.9	0.207
	1 1/4	1.250	90	58	175	0.200	30	0.500	2	0.216
	1 1/2	1.500	90	58	178	0.200	20	Edge Start		0.237
	2	2.000	90	58	203	0.250	10	Edge Start		0.268

200A Mild Steel O ₂ /Air									
Material Thickness		Cut Flow		Arc Voltage	Torch Working Height	Travel Speed	Initial Piercing Height	Pierce Delay	Kerf Width @ Rec. Speed
		Plasma (O ₂)	Shield (Air)						
(mm)		(Bar)	(Bar)	Volts	(mm) ±0.1	(mm/min)	(mm)	(sec)	(mm)
6		6.2	4.0	154	3.6	4830	7.6	0.1	3.9
8		6.2	4.0	155	3.6	4170	7.6	0.2	4.0
10		6.2	4.0	156	3.6	3400	7.8	0.3	4.1
12		6.2	4.0	158	3.6	2760	8.6	0.4	4.2
15		6.2	4.0	160	3.6	1990	8.9	0.5	4.5
20		6.2	4.0	168	4.1	1450	12.7	0.6	4.9
25		6.2	4.0	170	4.5	1050	12.7	0.9	5.2
32		6.2	4.0	175	5.1	750	12.7	2.1	5.5
38		6.2	4.0	178	5.1	510	Edge Start		6.0
44		6.2	4.0	190	5.7	390	Edge Start		6.4
50		6.2	4.0	201	6.3	270	Edge Start		6.8

Bold type indicates maximum piercing parameters. **Bold italic** indicates edge starts only.

Mild Steel

300A

Air Plasma / Air Shield

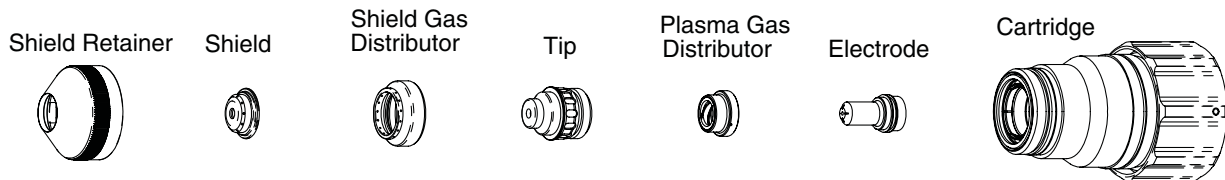

This Art Is For Reference ONLY

Art # A-07917_AB

Shield Retainer	Shield Cap	Shield Gas Distributor	Tip	Plasma Gas Distributor	Electrode	Cartridge
35-1021	35-1037	35-1283	35-1050	35-1044	35-1088	35-1022

Material Thickness			Cut Flow Rates /		Arc Voltage	Torch Working Height	Travel Speed	Initial Piercing Height	Pierce Delay	Kerf Width @ Rec. Speed
			Plasma (Air)	Shield (Air)						
(ga)	(in)	inch	(PSI)	(PSI)	Volts	(in) ±0.005	(ipm)	(in)	(sec)	(in)
	3/4	0.750	90	80	166	0.150	75	0.350	0.4	0.210
	7/8	0.875	90	80	172	0.150	65	0.400	0.6	0.220
	1	1.000	90	80	175	0.150	55	0.400	1.0	0.230
	1.25	1.250	90	80	184	0.250	40	0.500	1.8	0.260
	1.5	1.500	90	80	193	0.250	20	0.500	3.0	0.300
	1.75	1.750	90	80	203	0.350	15	Edge Start		0.325
	2	2.000	90	80	210	0.350	10	Edge Start		0.355
	2 1/4	2.250	90	80	215	0.350	6	Edge Start		0.360
	2 3/4	2.750	120	90	252	0.350	4	Edge Start		NA

Material Thickness		Cut Flow Rates /		Arc Voltage	Torch Working Height	Travel Speed	Initial Piercing Height	Pierce Delay	Kerf Width @ Rec. Speed
		Plasma (Air)	Shield (Air)						
(mm)	(mm)	(Bar)	(Bar)	Volts	(mm) ±0.1	(mm/min)	(mm)	(sec)	(mm)
20		6.2	5.5	168	3.8	1830	9.3	0.5	5.4
25		6.2	5.5	175	3.8	1430	10.2	0.9	5.8
30		6.2	5.5	184	6.4	1020	12.7	1.8	6.6
40		6.2	5.5	196	7.1	470	Edge Start		7.8
50		6.2	5.5	209	8.7	270	Edge Start		8.9
60		6.2	5.5	222	8.7	130	Edge Start		9.0
70		8.2	6.2	253	8.7	100	Edge Start		6.0

BOLD TYPE indicates maximum piercing parameters.

BOLD ITALIC indicates edge starts only.

Stainless Steel

55A

Air Plasma / Air Shield

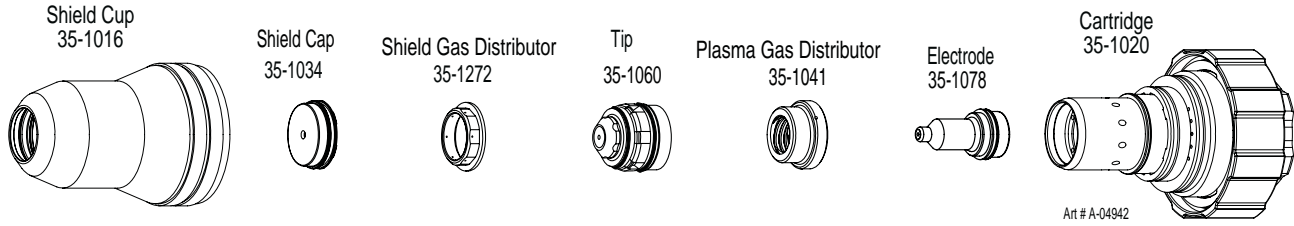

55A Stainless Steel (Air/Air)										
Material Thickness			Cut Flow Pressures		Arc Voltage	Torch Working Height	Travel Speed	Initial Piercing Height	Pierce Delay	Kerf Width @ Rec. Speed
			Plasma (Air)	Shield (Air)						
(ga)	(in)	inch	(PSI)	(PSI)	Volts	(in) ±0.005	(ipm)	(in)	(sec)	(in)
21		0.034	70	20	104	0.125	600	0.200	0.0	0.067
16		0.063	70	50	105	0.150	350	0.200	0.0	0.068
10		0.141	70	50	110	0.150	100	0.200	0.1	0.086
	3/16	0.188	70	50	112	0.150	60	0.200	0.1	0.086
	1/4	0.250	70	50	112	0.150	40	0.200	0.2	0.088

55A Stainless Steel (Air/Air)										
Material Thickness			Cut Flow Pressures		Arc Voltage	Torch Working Height	Travel Speed	Initial Piercing Height	Pierce Delay	Kerf Width @ Rec. Speed
			Plasma (Air)	Shield (Air)						
(mm)	(mm)	(mm)	(Bar)	(Bar)	Volts	(mm) ±0.1	(mm/min)	(mm)	(sec)	(mm)
0.8			4.8	1.4	104	3.2	15240	5.1	0.0	1.7
1			4.8	1.4	104	3.3	14060	5.1	0.0	1.7
1.5			4.8	3.4	105	3.7	9750	5.1	0.0	1.7
2			4.8	3.4	106	3.8	7610	5.1	0.0	1.8
3			4.8	3.4	109	3.8	4400	5.1	0.1	2.1
4			4.8	3.4	111	3.8	2180	5.1	0.1	2.2
5			4.8	3.4	112	3.8	1450	5.1	0.1	2.2
6			4.8	3.4	112	3.8	1130	5.1	0.2	2.2

Stainless Steel

100A

Air Plasma / Air Shield

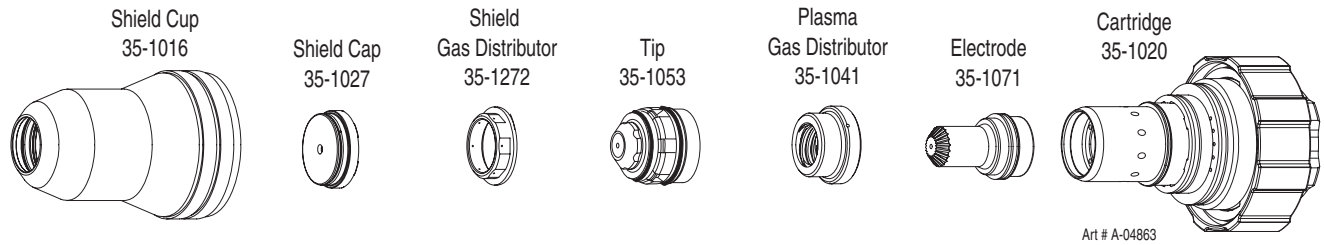

100A Stainless Steel (Air/Air)										
Material Thickness			Cut Flow Pressures		Arc Voltage	Torch Working Height	Travel Speed	Initial Piercing Height	Pierce Delay	Kerf Width @ Rec. Speed
			Plasma (Air)	Shield (Air)						
(ga)	(in)	inch	(PSI)	(PSI)	Volts	(in) ±0.005	(ipm)	(in)	(sec)	(in)
16		0.063	85	42	144	0.080	500	0.200	0.0	0.099
10		0.141	85	42	150	0.100	225	0.325	0.0	0.102
	3/16	0.188	85	42	153	0.140	175	0.325	0.1	0.105
	1/4	0.250	85	42	155	0.140	100	0.325	0.1	0.105
	3/8	0.375	85	42	160	0.140	65	0.325	0.2	0.110
	1/2	0.500	85	42	166	0.160	45	0.325	0.4	0.112
	5/8	0.625	85	42	165	0.160	35	0.350	1.0	0.114

100A Stainless Steel (Air/Air)									
Material Thickness		Cut Flow Pressures		Arc Voltage	Torch Working Height	Travel Speed	Initial Piercing Height	Pierce Delay	Kerf Width @ Rec. Speed
		Plasma (Air)	Shield (Air)						
(mm)		(Bar)	(Bar)	Volts	(mm) ±0.1	(mm/min)	(mm)	(sec)	(mm)
1.5		5.7	2.9	144	2.0	12700	5.1	0.0	2.4
2		5.7	2.9	145	2.1	11290	5.7	0.0	2.5
3		5.7	2.9	149	2.0	6330	8.3	0.0	2.6
4		5.7	2.9	150	3.6	7030	8.3	0.1	2.7
5		5.7	2.9	153	3.6	4170	8.3	0.1	2.7
6		5.7	2.9	155	3.6	2960	8.3	0.1	2.7
8		5.7	2.9	158	3.6	2080	8.3	0.2	2.7
10		5.7	2.9	161	3.6	1580	8.3	0.2	2.8
12		5.7	2.9	165	4.0	1260	8.3	0.4	2.8
15		5.7	2.9	165	4.1	960	8.7	0.8	2.9

Stainless Steel

100A

H35 Plasma / N₂ Shield

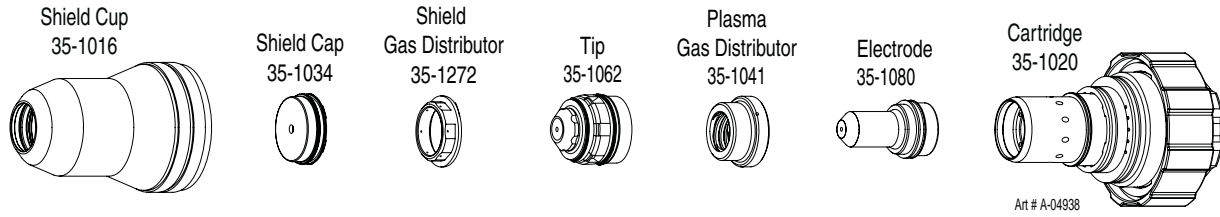

100A Stainless Steel (H35/N ₂)										
Material Thickness			Cut Flow Pressures		Arc Voltage	Torch Working Height	Travel Speed	Initial Piercing Height	Pierce Delay	Kerf Width @ Rec. Speed
			Plasma (H35)	Shield (N ₂)						
(ga)	(in)	inch	(PSI)	(PSI)	Volts	(in) ±0.005	(ipm)	(in)	(sec)	(in)
	3/8	0.375	100	80	145	0.130	50	0.250	0.3	0.090
	1/2	0.500	100	80	148	0.130	37	0.250	0.5	0.100
	5/8	0.625	100	80	155	0.140	26	0.250	0.6	0.115

Material Thickness		Cut Flow Pressures		Arc Voltage	Torch Working Height	Travel Speed	Initial Piercing Height	Pierce Delay	Kerf Width @ Rec. Speed
		Plasma (H35)	Shield (N ₂)						
(mm)		(Bar)	(Bar)	Volts	(mm) ±0.1	(mm/min)	(mm)	(sec)	(mm)
10		6.9	5.5	145	3.3	1220	6.4	0.3	2.3
12		6.9	5.5	147	3.3	1010	6.4	0.5	2.5
15		6.9	5.5	151	3.5	740	6.4	0.6	2.8

Stainless Steel

100A

N₂ Plasma / H₂O Shield

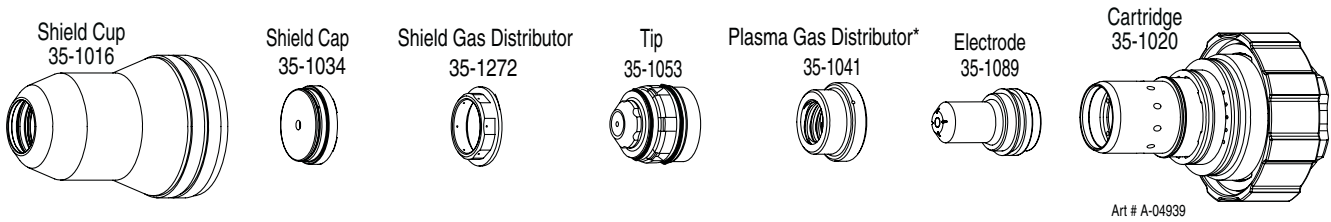

100A Stainless Steel (N ₂ /H ₂ O)										
Material Thickness			Cut Flow Pressures		Arc Voltage	Torch Working Height	Travel Speed	Initial Piercing Height	Pierce Delay	Kerf Width @ Rec. Speed
			Plasma (N ₂)	Shield (H ₂ O)						
(ga)	(in)	inch	(PSI)	Ball *	Volts	(in) ±0.005	(ipm)	(in)	(sec)	(in)
10		0.141	100	5	160	0.125	160	0.200	0.000	0.074
	3/16	0.188	100	5	157	0.125	100	0.250	0.300	0.080
	1/4	0.250	100	5	155	0.125	60	0.250	0.300	0.086
	3/8	0.375	100	5	159	0.125	50	0.250	0.300	0.087
	1/2	0.500	100	5	169	0.130	35	0.300	0.500	0.100
	5/8	0.625	100	5	175	0.140	30	0.300	0.600	0.110
	3/4	0.750	100	5	177	0.150	25	Edge Start		**0.125

** Note measured, extrapolated value.

Material Thickness		Cut Flow Pressures		Arc Voltage	Torch Working Height	Travel Speed	Initial Piercing Height	Pierce Delay	Kerf Width @ Rec. Speed
		Plasma (N ₂)	Shield (H ₂ O)						
(mm)		(Bar)	Ball *	Volts	(mm) ±0.1	(mm/min)	(mm)	(sec)	(mm)
3		6.9	5	161	3.2	4810	4.5	0	1.8
4		6.9	5	159	3.2	3530	5.5	0.1	1.9
5		6.9	5	157	3.2	2400	6.4	0.3	2.1
6		6.9	5	155	3.2	1750	6.4	0.3	2.2
8		6.9	5	157	3.2	1390	6.4	0.3	2.2
10		6.9	5	160	3.2	1210	6.5	0.3	2.3
12		6.9	5	167	3.3	970	7.3	0.5	2.5
15		6.9	5	173	3.5	800	7.6	0.6	2.7
20		6.9	5	178	3.9	600	Edge Start		3.3

* Ball setting for shield water is set using a line pressure of 55 PSI / 3.8 Bar

NOTE: Ohmic height sensing is not recommended with water shield.
Water on the plate interferes electrically with the ohmic sensing system.

Stainless Steel

200A

Air Plasma / Air Shield

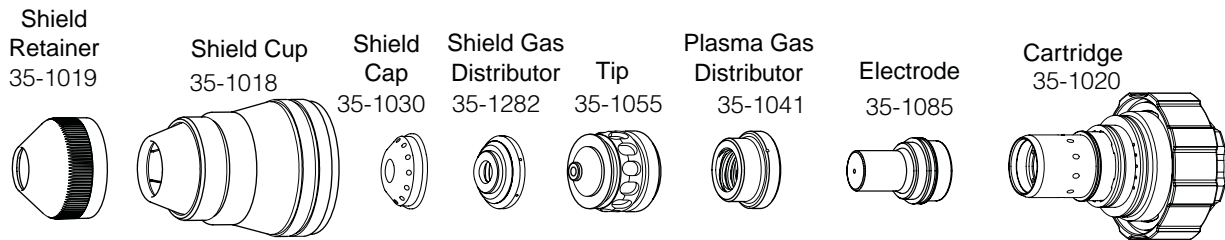

Art # A-07594

200A Stainless Steel Air/Air										
Material Thickness			Cut Flow Pressures		Arc Voltage	Torch Working Height	Travel Speed	Initial Piercing Height	Pierce Delay	Kerf Width @ Rec. Speed
			Plasma (Air)	Shield (Air)						
(ga)	(in)	inch	(PSI)	(PSI)	Volts	(in) ±0.005	(ipm)	(in)	(sec)	(in)
	3/16	0.1875	90	70	168	0.140	300	0.300	0	0.169
	1/4	0.250	90	70	165	0.140	275	0.300	0.1	0.162
	3/8	0.375	90	70	167	0.140	200	0.300	0.2	0.169
	1/2	0.500	90	70	170	0.140	145	0.350	0.3	0.169
	5/8	0.625	90	70	170	0.140	110	0.400	0.4	0.174
	3/4	0.750	90	70	171	0.160	75	0.450	0.5	0.176
	7/8	0.875	90	70	172	0.170	55	0.450	0.7	0.181
	1	1.000	90	70	175	0.180	40	0.500	1.3	0.181
	1 1/4	1.250	90	70	185	0.200	20	0.500	3	0.207
	1 1/2	1.500	90	70	191	0.200	13	Edge Start		0.220
	2	2.000	90	70	198	0.200	8	Edge Start		0.230

200A Stainless Steel Air/Air										
Material Thickness			Cut Flow Pressures		Arc Voltage	Torch Working Height	Travel Speed	Initial Piercing Height	Pierce Delay	Kerf Width @ Rec. Speed
			Plasma (Air)	Shield (Air)						
(mm)	(mm)	(mm)	(Bar)	(Bar)	Volts	(mm) ±0.1	(mm/min)	(mm)	(sec)	(mm)
	5	5	6.2	4.8	168	3.6	7530	7.6	0	4.1
	6	6	6.2	4.8	166	3.6	7130	7.6	0.1	4.1
	8	8	6.2	4.8	166	3.6	6000	7.6	0.2	4.2
	10	10	6.2	4.8	166	3.6	4870	7.8	0.2	4.3
	12	12	6.2	4.8	169	3.6	3990	8.6	0.3	4.3
	15	15	6.2	4.8	170	3.6	3040	9.8	0.4	4.4
	20	20	6.2	4.8	171	4.1	1750	11.4	0.6	4.5
	25	25	6.2	4.8	175	4.5	1060	12.5	1.2	4.6
	32	32	6.2	4.8	185	5.1	500	12.7	3.0	5.3
	38	38	6.2	4.8	191	5.1	330	Edge Start		5.6
	50	50	6.2	4.8	198	5.1	210	Edge Start		5.8

Stainless Steel

200A

H35 Plasma / N₂ Shield **

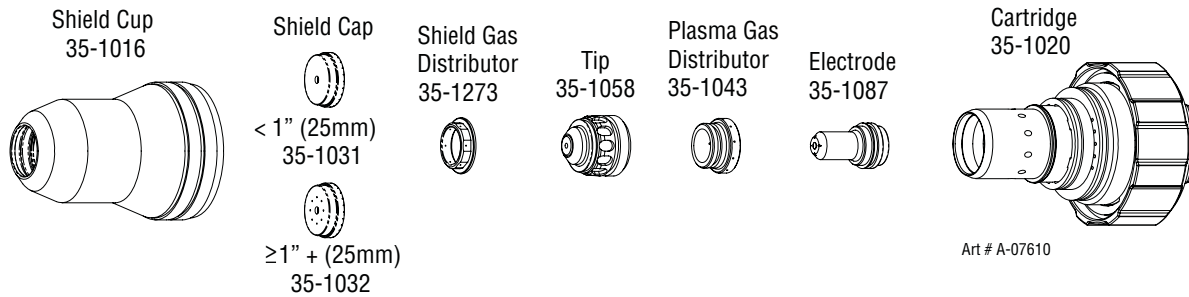

200A Stainless Steel (H35/N ₂)										
Material Thickness			Cut Flow		Arc Voltage	Torch Working Height	Travel Speed	Initial Piercing Height*	Pierce Delay	Kerf Width @ Rec. Speed
			Plasma (H35)	Shield (N ₂)						
(ga)	(in)	inch	(PSI)	(PSI)	Volts	(in) ±0.005	(ipm)	(in)	(sec)	(in)
	3/8	0.375	70	120	157	0.240	90	0.300	0.5	0.158
	1/2	0.5	70	120	160	0.260	65	0.300	0.6	0.171
	5/8	0.625	70	120	165	0.280	50	0.350	0.7	0.178
	3/4	0.75	70	120	168	0.300	40	0.450	0.8	0.180
	7/8	0.875	70	120	172	0.300	30	0.450	0.9	0.178
	1	1	70	120	175	0.325	25	0.450	1.3	0.185
	1 1/4	1.25	70	120	180	0.300	20	Edge Start		0.175
	1 1/2	1.5	70	120	182	0.300	15	Edge Start		0.180
	2	2	70	120	185	0.325	10	Edge Start		0.195

Material Thickness		Cut Flow		Arc Voltage	Torch Working Height	Travel Speed	Initial Piercing Height*	Pierce Delay	Kerf Width @ Rec. Speed
		Plasma (H35)	Shield (N ₂)						
(mm)		(Bar)	(Bar)	Volts	(mm) ±0.1	(mm/min)	(mm)	(sec)	(mm)
10		4.8	8.3	157	6.2	2190	7.6	0.5	4.1
12		4.8	8.3	159	6.5	1790	7.6	0.6	4.3
15		4.8	8.3	164	7.3	1380	8.5	0.7	4.5
20		4.8	8.3	169	7.8	940	11.4	0.8	4.6
25		4.8	8.3	175	8.3	650	11.4	1.2	4.7
32		4.8	8.3	180	8.3	500	Edge Start		4.5
38		4.8	8.3	182	8.3	380	Edge Start		4.6
50		4.8	8.3	185	8.3	260	Edge Start		4.9

* Lock pierce height between 0.5" to 1" to avoid torch hitting the pierce metal puddle.

**Requires Firmware version 3.2 or higher.

Stainless Steel 200A

N₂ Plasma / H₂O Shield



This Graphic Is For Reference ONLY

Shield Cup	Shield Cap	Shield Gas Distributor	Tip	Plasma Gas Distributor	Electrode	Cartridge
35-1016	35-1039	35-1273	35-1064	35-1046	35-1089	35-1020

Material Thickness			Cut Flows / Pressures		Arc Voltage	Torch Working Height	Travel Speed	Initial Piercing Height	Pierce Delay	Kerf Width @ Rec. Speed
			Plasma (N ₂)	Shield (H ₂ O)*						
(ga)	(in)	inch	(PSI)	(Ball)	Volts	(in) ±0.005	(ipm)	(in)	(sec)	(in)
	1/2	0.500	90	5	170	0.160	90	0.300	0.4	0.117
	5/8	0.625	90	5	173	0.200	75	0.300	0.5	0.128
	3/4	0.750	110	5	175	0.250	60	0.300	0.6	0.132
	7/8	0.875	110	5	180	0.250	50	0.300	0.7	0.141
	1	1.000	110	5	185	0.300	40	0.350	1.0	0.151
	1.25	1.250	110	5	189	0.350	30	Edge Start		0.163
	1.5	1.500	110	5	202	0.350	20	Edge Start		0.175
	1.75	1.750	110	5	205	0.400	15	Edge Start		0.180

Material Thickness			Cut Flows / Pressures		Arc Voltage	Torch Working Height	Travel Speed	Initial Piercing Height	Pierce Delay	Kerf Width @ Rec. Speed
			Plasma (N ₂)	Shield (H ₂ O)*						
(mm)	(mm)	(mm)	(Bar)	(Ball)	Volts	(mm) ±0.1	(mm/min)	(mm)	(sec)	(mm)
	12	12	6.2	5	169	4.1	2300	7.6	0.4	2.9
	15	15	6.2	5	173	5.0	1950	7.6	0.5	3.2
	20	20	7.6	5	178	6.4	1450	7.6	0.6	3.4
	25	25	7.6	5	185	7.6	1000	8.9	1.0	3.8
	32	32	7.6	5	190	8.9	750	Edge Start		4.1
	38	38	7.6	5	202	8.9	500	Edge Start		4.4
	44	44	7.6	5	205	10.2	380	Edge Start		4.6

BOLD TYPE indicates maximum piercing parameters. **BOLD ITALIC** indicates edge starts only.

Requires CCM version 3.4 or later. Requires GCM version 3.2 or later.

* Pressure of the water supply line should be regulated at 55 PSI / 3.4 Bar by customer pressure regulator.

Note1: Ohmic height sensing is not recommended with water shield. Water on the plate interferes electrically with the ohmic sensing circuit.

Note2: Water source used for shield must be demineralized.

Stainless Steel

300A

Air Plasma / Air Shield

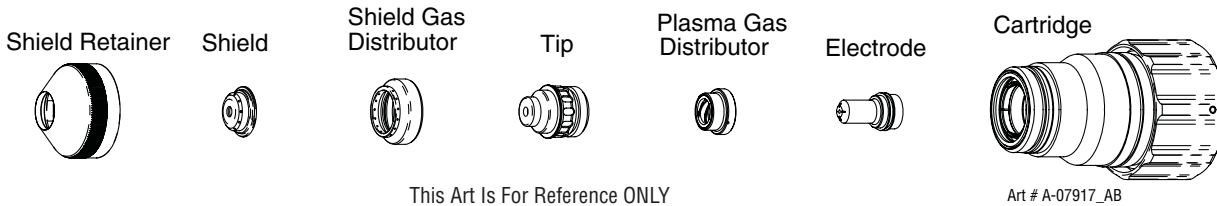

Shield Retainer	Shield Cap	Shield Gas Distributor	Tip	Plasma Gas Distributor	Electrode	Cartridge
35-1021	35-1037	35-1283	35-1050	35-1044	35-1088	35-1022

Material Thickness			Cut Flow Rates /		Arc Voltage	Torch Working Height	Travel Speed	Initial Piercing Height	Pierce Delay	Kerf Width @ Rec. Speed
			Plasma (Air)	Shield (Air)						
(ga)	(in)	inch	(PSI)	(PSI)	Volts	(in) ±0.005	(ipm)	(in)	(sec)	(in)
	3/4	0.750	90	80	179	0.300	100	0.400	0.5	0.125
	7/8	0.875	90	80	182	0.300	75	0.400	0.7	0.133
	1	1.000	90	80	190	0.300	60	0.400	0.8	0.166
	1.25	1.250	90	80	193	0.300	40	0.500	3.0	0.200
	1.5	1.500	90	80	196	0.300	15	0.500	10.0	0.220
	1.75	1.750	90	80	206	0.300	8	Edge Start		0.265

Material Thickness			Cut Flow Rates /		Arc Voltage	Torch Working Height	Travel Speed	Initial Piercing Height	Pierce Delay	Kerf Width @ Rec. Speed
			Plasma (Air)	Shield (Air)						
(mm)	(mm)	(mm)	(Bar)	(Bar)	Volts	(mm) ±0.1	(mm/min)	(mm)	(sec)	(mm)
	20	20	6.2	5.5	178	7.6	2330	10.2	0.5	3.2
	25	25	6.2	5.5	190	7.6	1520	10.2	0.8	4.2
	30	30	6.2	5.5	192	7.6	1010	12.7	3.0	5.1
	40	40	6.2	5.5	197	7.6	810	12.7	10.0	5.6
	50	50	6.2	5.5	210	7.6	100	Edge Start		7.0

BOLD TYPE indicates maximum piercing parameters.

BOLD ITALIC indicates edge starts only.

Aluminum

55A

Air Plasma / Air Shield

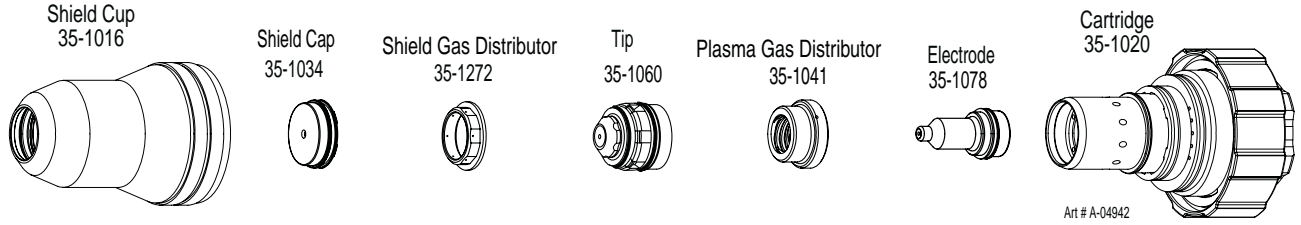

55A Aluminum (Air/Air)										
Material Thickness			Cut Flow Pressures		Arc Voltage	Torch Working Height	Travel Speed	Initial Piercing Height	Pierce Delay	Kerf Width @ Rec. Speed
			Plasma (Air)	Shield (Air)						
(ga)	(in)	inch	(PSI)	(PSI)	Volts	(in) ±0.005	(ipm)	(in)	(sec)	(in)
23		0.031	70	50	100	0.100	600	0.150	0.0	0.066
16		0.064	70	50	105	0.100	400	0.200	0.0	0.070
10		0.135	70	50	115	0.150	140	0.200	0.0	0.084
	3/16	0.188	70	50	120	0.150	100	0.200	0.0	0.084
	1/4	0.250	70	50	122	0.150	50	0.200	0.1	0.089

55A Aluminum (Air/Air)									
Material Thickness		Cut Flow Pressures		Arc Voltage	Torch Working Height	Travel Speed	Initial Piercing Height	Pierce Delay	Kerf Width @ Rec. Speed
		Plasma (Air)	Shield (Air)						
(mm)		(Bar)	(Bar)	Volts	(mm) ±0.1	(mm/min)	(mm)	(sec)	(mm)
1		4.8	3.4	101	2.5	13950	4.1	0.0	1.7
2		4.8	3.4	107	2.8	8790	5.1	0.0	1.9
3		4.8	3.4	113	3.5	5130	5.1	0.0	2.0
4		4.8	3.4	117	3.8	3130	5.1	0.0	2.1
5		4.8	3.4	120	3.8	2360	5.1	0.0	2.2
6		4.8	3.4	122	3.8	1550	5.1	0.1	2.2

Aluminum

100A

Air Plasma / Air Shield

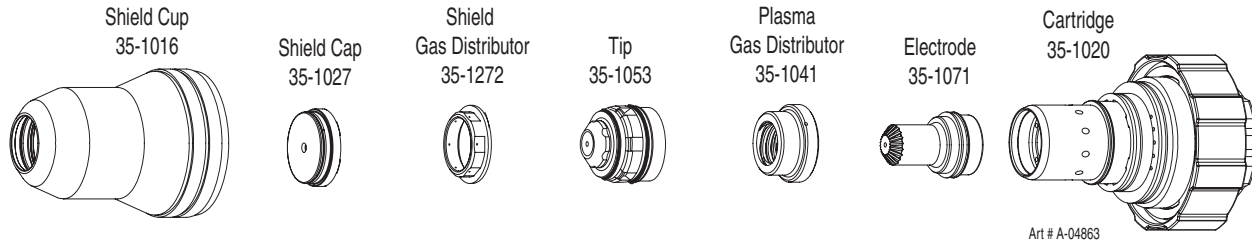

100A Aluminum (Air/Air)										
Material Thickness			Cut Flow Pressures		Arc Voltage	Torch Working Height	Travel Speed	Initial Piercing Height	Pierce Delay	Kerf Width @ Rec. Speed
			Plasma (Air)	Shield (Air)						
(ga)	(in)	inch	(PSI)	(PSI)	Volts	(in) ±0.005	(ipm)	(in)	(sec)	(in)
16		0.064	85	42	154	0.130	500	0.200	0.0	0.103
10		0.135	85	42	157	0.130	260	0.200	0.0	0.106
	3/16	0.188	85	42	156	0.130	120	0.325	0.1	0.100
	1/4	0.250	85	42	158	0.140	100	0.325	0.2	0.104
	3/8	0.375	85	42	162	0.140	75	0.325	0.2	0.107
	1/2	0.500	85	42	168	0.140	45	0.325	0.3	0.109
	5/8	0.625	85	42	175	0.140	35	0.325	0.4	0.112
	3/4	0.750	85	42	180	0.180	35	0.350	1.0	0.121

Material Thickness		Cut Flow Pressures		Arc Voltage	Torch Working Height	Travel Speed	Initial Piercing Height	Pierce Delay	Kerf Width @ Rec. Speed
		Plasma (Air)	Shield (Air)						
(mm)		(Bar)	(Bar)	Volts	(mm) ±0.1	(mm/min)	(mm)	(sec)	(mm)
2		5.9	2.9	155	3.3	11430	5.1	0.0	2.6
3		5.9	2.9	156	3.3	8050	5.1	0.0	2.7
4		5.9	2.9	157	3.3	5100	6.4	0.0	2.6
5		5.9	2.9	156	3.3	2980	8.3	0.1	2.6
6		5.9	2.9	158	3.5	2650	8.3	0.2	2.6
8		5.9	2.9	160	3.6	2210	8.3	0.2	2.7
10		5.9	2.9	163	3.6	1790	8.3	0.2	2.7
12		5.9	2.9	167	3.6	1310	8.3	0.3	2.8
15		5.9	2.9	173	3.6	960	8.3	0.4	2.8
20		5.9	2.9	181	4.9	890	9.9	1.0	3.1

Aluminum

100A

H35 Plasma / N₂ Shield

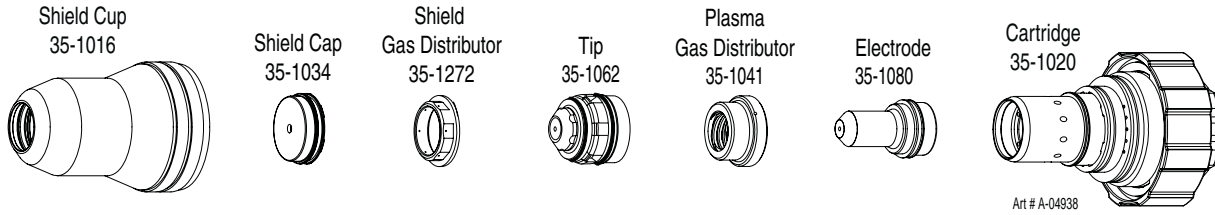

100A Aluminum (H35/N ₂)										
Material Thickness			Cut Flow Pressures		Arc Voltage	Torch Working Height	Travel Speed	Initial Piercing Height	Pierce Delay	Kerf Width @ Rec. Speed
			Plasma (H35)	Shield (N ₂)						
(ga)	(in)	inch	(PSI)	(PSI)	Volts	(in) ±0.005	(ipm)	(in)	(sec)	(in)
	3/8	0.375	120	50	150	0.188	60	0.350	0.1	0.100
	1/2	0.500	120	50	156	0.188	40	0.350	0.4	0.110
	5/8	0.625	120	50	160	0.188	30	0.350	0.5	0.113
	3/4	0.750	120	50	171	0.250	20	0.350	0.6	0.130

100A Aluminum (H35/N ₂)									
Material Thickness		Cut Flow Pressures		Arc Voltage	Torch Working Height	Travel Speed	Initial Piercing Height	Pierce Delay	Kerf Width @ Rec. Speed
		Plasma (H35)	Shield (N ₂)						
(mm)	(mm)	(PSI)	(PSI)	Volts	(mm) ±0.1	(mm/min)	(mm)	(sec)	(mm)
10	10	8.3	3.4	151	4.8	1450	8.9	0.1	2.6
12	12	8.3	3.4	155	4.8	1130	8.9	0.3	2.7
15	15	8.3	3.4	159	4.8	830	8.9	0.5	2.8
20	20	8.3	3.4	174	6.8	430	8.9	0.6	3.4

Aluminum

100A

N₂ Plasma / H₂O Shield

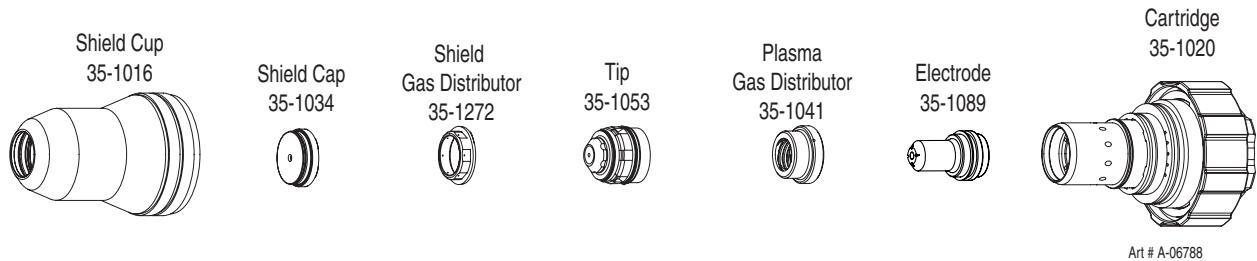

Art # A-06788

100A Aluminum (N ₂ /H ₂ O)										
Material Thickness			Cut Flow Pressures		Arc Voltage	Torch Working Height	Travel Speed	Initial Piercing Height	Pierce Delay	Kerf Width @ Rec. Speed
			Plasma (N ₂)	Shield (H ₂ O)						
(ga)	(in)	inch	(PSI)	Ball *	Volts	(in) ±0.005	(ipm)	(in)	(sec)	(in)
10		0.135	100	5	148	0.125	170	0.200	0.0	0.072
	3/16	0.188	100	5	158	0.125	80	0.250	0.3	0.080
	1/4	0.250	100	5	158	0.125	60	0.250	0.3	0.085
	3/8	0.375	100	5	161	0.125	50	0.250	0.3	0.086
	1/2	0.500	100	5	170	0.130	35	0.300	0.6	0.091
	5/8	0.625	100	5	180	0.140	20	0.300	0.8	0.120

Material Thickness		Cut Flow Pressures		Arc Voltage	Torch Working Height	Travel Speed	Initial Piercing Height	Pierce Delay	Kerf Width @ Rec. Speed
		Plasma (N ₂)	Shield (H ₂ O)						
(mm)		(Bar)	Ball *	Volts	(mm) ±0.1	(mm/min)	(mm)	(sec)	(mm)
4		6.9	5	152	3.2	3350	5.6	0.1	1.9
5		6.9	5	158	3.2	1960	6.4	0.3	2.1
6		6.9	5	158	3.2	1640	6.4	0.3	2.1
8		6.9	5	160	3.2	1390	6.4	0.3	2.2
10		6.9	5	162	3.2	1210	6.5	0.3	2.2
12		6.9	5	168	3.3	970	7.3	0.5	2.3
15		6.9	5	177	3.5	610	7.6	0.7	2.8

* Ball setting for shield water is set using a line pressure of 55 PSI / 3.8 Bar

NOTE: Ohmic height sensing is not recommended with water shield.
Water on the plate interferes electrically with the ohmic sensing system.

Aluminum

200A

Air Plasma / Air Shield

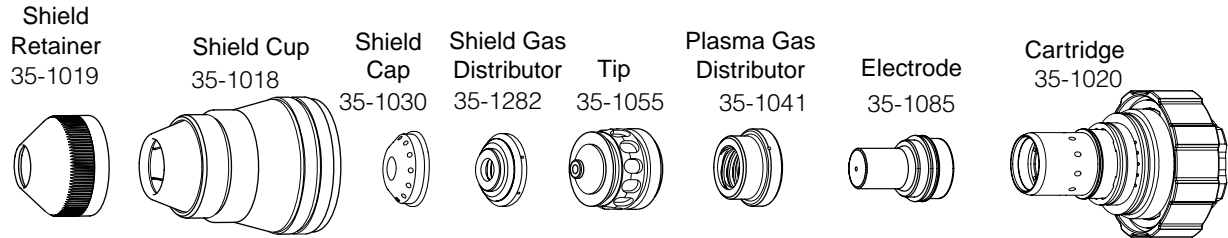

Art # A-07594

200A Aluminum Air/Air										
Material Thickness			Cut Flow Pressures		Arc Voltage	Torch Working Height	Travel Speed	Initial Piercing Height	Pierce Delay	Kerf Width @ Rec. Speed
			Plasma (Air)	Shield (Air)						
(ga)	(in)	inch	(PSI)	(PSI)	Volts	(in) ±0.005	(ipm)	(in)	(sec)	(in)
	3/16	0.1875	90	70	170	0.14	225	0.300	0.0	0.173
	1/4	0.250	90	70	174	0.140	195	0.300	0.1	0.177
	3/8	0.375	90	70	179	0.140	150	0.300	0.2	0.173
	1/2	0.500	90	70	181	0.140	115	0.350	0.3	0.166
	5/8	0.625	90	70	182	0.140	90	0.400	0.4	0.164
	3/4	0.750	90	70	185	0.160	70	0.400	0.5	0.171
	7/8	0.875	90	70	189	0.170	55	0.450	0.7	0.175
	1	1.000	90	70	196	0.180	40	0.500	1.3	0.197
	1 1/4	1.250	90	70	205	0.200	25	0.500	3.0	0.185
	1 1/2	1.500	90	70	210	0.200	15	Edge Start		0.198
	2	2.000	90	70	213	0.200	8	Edge Start		0.220

200A Aluminum Air/Air									
Material Thickness		Cut Flow Pressures		Arc Voltage	Torch Working Height	Travel Speed	Initial Piercing Height	Pierce Delay	Kerf Width @ Rec. Speed
		Plasma (Air)	Shield (Air)						
(mm)	(mm)	(Bar)	(Bar)	Volts	(mm) ±0.1	(mm/min)	(mm)	(sec)	(mm)
	5	6.2	4.8	171	3.6	5600	7.6	0	4.4
	6	6.2	4.8	173	3.6	5120	7.6	0.1	4.5
	8	6.2	4.8	177	3.6	4360	7.6	0.2	4.4
	10	6.2	4.8	179	3.6	3680	7.8	0.2	4.4
	12	6.2	4.8	181	3.6	3120	8.6	0.3	4.3
	15	6.2	4.8	182	4.1	2460	9.8	0.4	4.2
	20	6.2	4.8	186	4.5	1660	10.5	0.6	4.4
	25	6.2	4.8	195	5.1	1060	12.5	1.2	4.6
	32	6.2	4.8	205	5.1	630	12.7	2.9	4.7
	38	6.2	4.8	210	5.1	390	Edge Start		5.0
	50	6.2	4.8	213	5.1	210	Edge Start		5.6

Aluminum

200A

H35 Plasma / N₂ Shield **

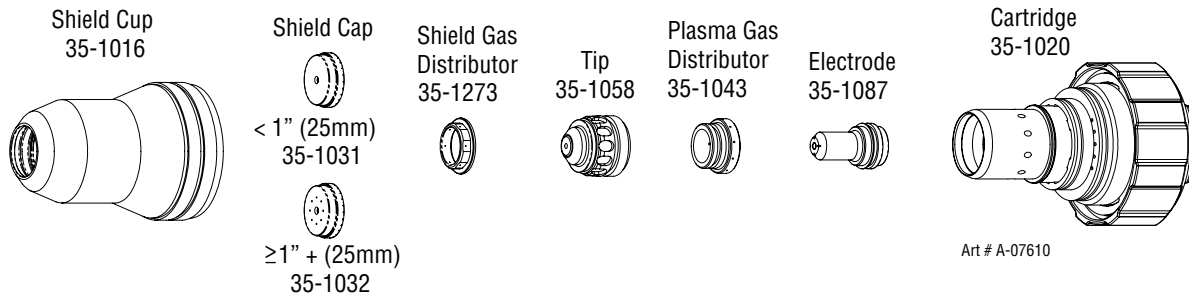

200A Aluminum (H35/N ₂)										
Material Thickness			Cut Flow		Arc Voltage	Torch Working Height	Travel Speed	Initial Piercing Height*	Pierce Delay	Kerf Width @ Rec. Speed
			Plasma (H35)	Shield (N ₂)						
(ga)	(in)	inch	(PSI)	(PSI)	Volts	(in) ±0.005	(ipm)	(in)	(sec)	(in)
	1/2	0.5	70	100	155	0.300	150	0.350	0.2	0.163
	5/8	0.625	70	100	160	0.300	110	0.350	0.3	0.169
	3/4	0.75	70	100	166	0.300	70	0.400	0.4	0.177
	7/8	0.875	70	100	171	0.350	55	0.450	0.5	0.192
	1	1	70	100	177	0.350	40	Edge Start		0.196
	1 1/4	1.25	70	100	181	0.350	32	Edge Start		0.180
	1 1/2	1.5	70	100	188	0.350	25	Edge Start		0.190
	2	2	70	100	190	0.350	15	Edge Start		0.195

Material Thickness		Cut Flow		Arc Voltage	Torch Working Height	Travel Speed	Initial Piercing Height*	Pierce Delay	Kerf Width @ Rec. Speed
		Plasma (H35)	Shield (N ₂)						
(mm)	(mm)	(Bar)	(Bar)	Volts	(mm) ±0.1	(mm/min)	(mm)	(sec)	(mm)
	12	4.8	6.9	155	7.6	3810	7.6	0.2	4.3
	15	4.8	6.9	159	7.6	3070	8.9	0.3	4.3
	20	4.8	6.9	167	8.0	1660	10.5	0.4	4.6
	25	4.8	6.9	176	8.9	1060	Edge Start		5.0
	32	4.8	6.9	181	8.9	810	Edge Start		4.6
	38	4.8	6.9	188	8.9	640	Edge Start		4.8
	50	4.8	6.9	190	8.9	400	Edge Start		4.9

* Lock pierce height for first 0.5" to 1" of cutting to avoid torch hitting the pierce metal puddle.

Slightly decreasing the shield gas pressure minimizes dross on aluminum cutting

**Requires Firmware version 3.2 or higher.

Aluminum 200A N₂ Plasma / H₂O Shield

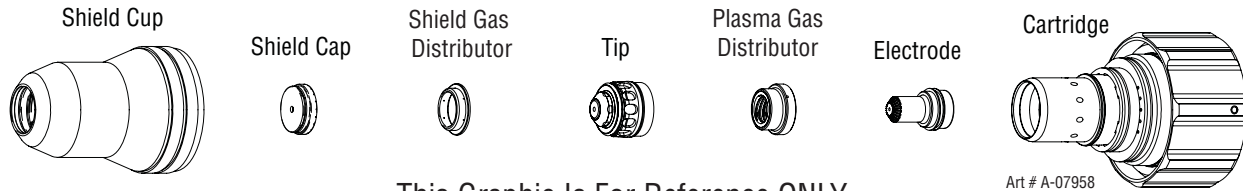

This Graphic Is For Reference ONLY

Shield Cup	Shield Cap	Shield Gas Distributor	Tip	Plasma Gas Distributor	Electrode	Cartridge
35-1016	35-1039	35-1273	35-1064	35-1046	35-1089	35-1020

Material Thickness			Cut Flows / Pressures		Arc Voltage	Torch Working Height	Travel Speed	Initial Piercing Height	Pierce Delay	Kerf Width @ Rec. Speed
			Plasma (N ₂)	Shield (H ₂ O)*						
(ga)	(in)	inch	(PSI)	(Ball)	Volts	(in) ±0.005	(ipm)	(in)	(sec)	(in)
	1/2	0.500	70	5	156	0.250	110	0.300	0.3	0.133
	5/8	0.625	70	5	165	0.250	100	0.300	0.4	0.140
	3/4	0.750	110	5	170	0.250	70	0.300	0.6	0.138
	7/8	0.875	110	5	178	0.300	60	0.350	0.8	0.152
	1	1.000	110	5	188	0.350	40	0.400	0.9	0.165
	1 1/4	1.250	110	5	197	0.350	30	0.400	1.9	0.175
	1 1/2	1.500	110	5	198	0.350	20	Edge Start		0.181
	1 3/4	1.750	110	5	198	0.350	18	Edge Start		0.188
	2	2.000	110	5	198	0.350	15	Edge Start		0.196

Material Thickness		Cut Flows / Pressures		Arc Voltage	Torch Working Height	Travel Speed	Initial Piercing Height	Pierce Delay	Kerf Width @ Rec. Speed
		Plasma (N ₂)	Shield (H ₂ O)*						
(mm)	(mm)	(Bar)	(Ball)	Volts	(mm) ±0.1	(mm/min)	(mm)	(sec)	(mm)
	12	4.9	5	155	6.4	2800	7.6	0.3	3.3
	15	4.9	5	163	6.4	2500	7.6	0.4	3.5
	20	7.6	5	171	6.4	1700	7.6	0.6	4.0
	25	7.6	5	187	8.0	1000	10.2	0.9	4.2
	32	7.6	5	197	8.9	750	10.2	1.9	4.4
	38	7.6	5	198	8.9	500	Edge Start		4.6
	44	7.6	5	198	8.9	450	Edge Start		4.8
	50	7.6	5	198	8.9	380	Edge Start		5.0

BOLD TYPE indicates maximum piercing parameters. **BOLD ITALIC** indicates edge starts only.

Requires CCM version 3.4 or later. Requires GCM version 3.2 or later.

* Pressure of the water supply line should be regulated at 55 PSI / 3.4 Bar by customer pressure regulator.

Note1: Ohmic height sensing is not recommended with water shield. Water on the plate interferes electrically with the ohmic sensing circuit.

Note2: Water source used for shield must be demineralized.

Aluminum

300A

Air Plasma / Air Shield

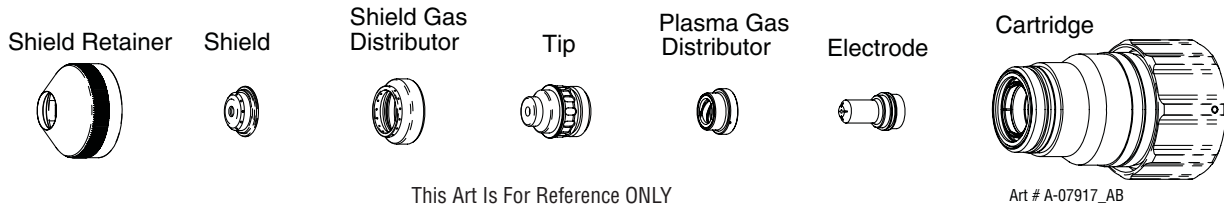

Shield Retainer	Shield Cap	Shield Gas Distributor	Tip	Plasma Gas Distributor	Electrode	Cartridge
35-1021	35-1037	35-1283	35-1050	35-1044	35-1088	35-1022

Material Thickness			Cut Flow Rates /		Arc Voltage	Torch Working Height	Travel Speed	Initial Piercing Height	Pierce Delay	Kerf Width @ Rec. Speed
			Plasma (Air)	Shield (Air)						
(ga)	(in)	inch	(PSI)	(PSI)	Volts	(in) ±0.005	(ipm)	(in)	(sec)	(in)
	3/4	0.750	90	80	179	0.200	90	0.350	0.4	0.220
	7/8	0.875	90	80	179	0.200	75	0.400	0.5	0.230
	1	1.000	90	80	180	0.200	70	0.400	0.7	0.240
	1.25	1.250	90	80	194	0.250	45	0.450	1.5	0.270
	1.5	1.500	90	80	200	0.250	20	0.450	2.2	0.300
	1.75	1.750	90	80	210	0.250	19	Edge Start		0.300
	2	2.000	90	80	220	0.250	18	Edge Start		0.300

Material Thickness			Cut Flow Rates /		Arc Voltage	Torch Working Height	Travel Speed	Initial Piercing Height	Pierce Delay	Kerf Width @ Rec. Speed
			Plasma (Air)	Shield (Air)						
(mm)	(mm)	(mm)	(Bar)	(Bar)	Volts	(mm) ±0.1	(mm/min)	(mm)	(sec)	(mm)
	20	20	6.2	5.5	179	5.1	2290	8.9	0.4	5.6
	25	25	6.2	5.5	180	5.1	1780	10.2	0.7	6.1
	30	30	6.2	5.5	192	6.4	1140	11.4	1.5	7.0
	40	40	6.2	5.5	201	6.4	510	11.4	2.2	7.6
	50	50	6.2	5.5	219	6.4	460	Edge Start		7.6

BOLD TYPE indicates maximum piercing parameters.

BOLD ITALIC indicates edge starts only.

TORCH REPLACEMENT PARTS

Returns

If a product must be returned for service, contact your authorized distributor. Materials returned without proper authorization will not be accepted.

Ordering Information

Order replacement parts by catalog number and complete description of the part or assembly. Also include the model and serial number of the machine or torch.

Refer to parts diagrams within the body of the manual for consumable parts and replacement O-Ring catalog numbers.

Qty.	Description	Catalog Number
1	XT-301 Torch w/ 25' / 7.6 m Leads, w/ 100-Amp Mild Steel Consumables	2-7000
1	XT-301 Torch w/ 35' / 10.6 m Leads, w/ 100-Amp Mild Steel Consumables	2-7001
1	XT-301 Torch w/ 50' / 15.2 m Leads, w/ 100-Amp Mild Steel Consumables	2-7002
1	XT-301 Torch w/ 75' / 22.9 m Leads, w/ 100-Amp Mild Steel Consumables	2-7003
1	XT-301 Torch w/ 100' / 30.5 m Leads, w/ 100-Amp Mild Steel Consumables	2-7004
1	O-Ring Lubricant (Christo-Lube MCG-129)	9-4893
1	Water Shield Regulator	8-6118
1	Consumables Tool	9-9431
1	Torch Cartridge (includes Consumables Tool)	35-1020
1	Shield Cup (all applications except 200-A Mild Steel)	35-1016

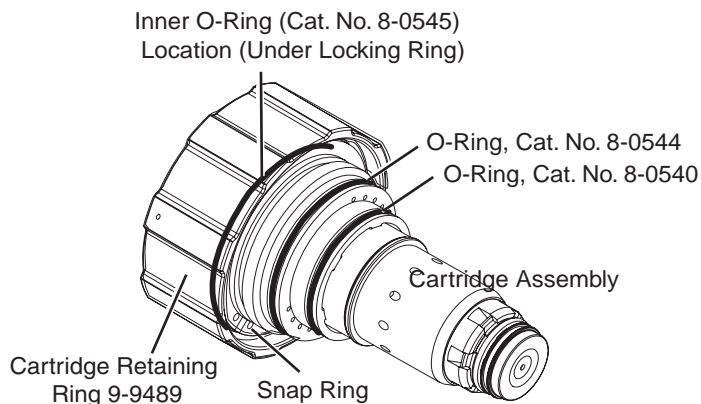

Art # A-07087

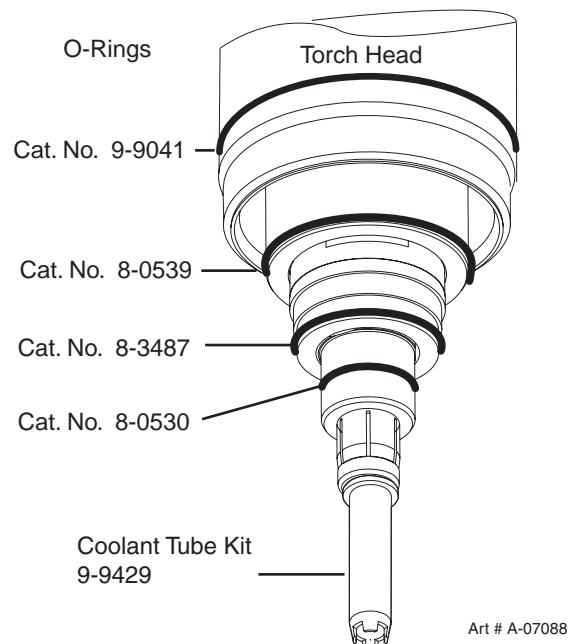

Art # A-07088

Qty.	Description	Catalog Number
1	XT-301 Torch Head Kit	35-1002
1	Torch Positioning Tube	9-4700
1	Torch Clamp Assembly	9-9336
1	Coolant Tube Kit	9-9429
1	Coolant Check Valve Kit	9-4846
1	Mounting Tube Hardware Kit (includes Mounting Tube O-ring)	9-4847
1	Ohmic Clip Kit	9-9414

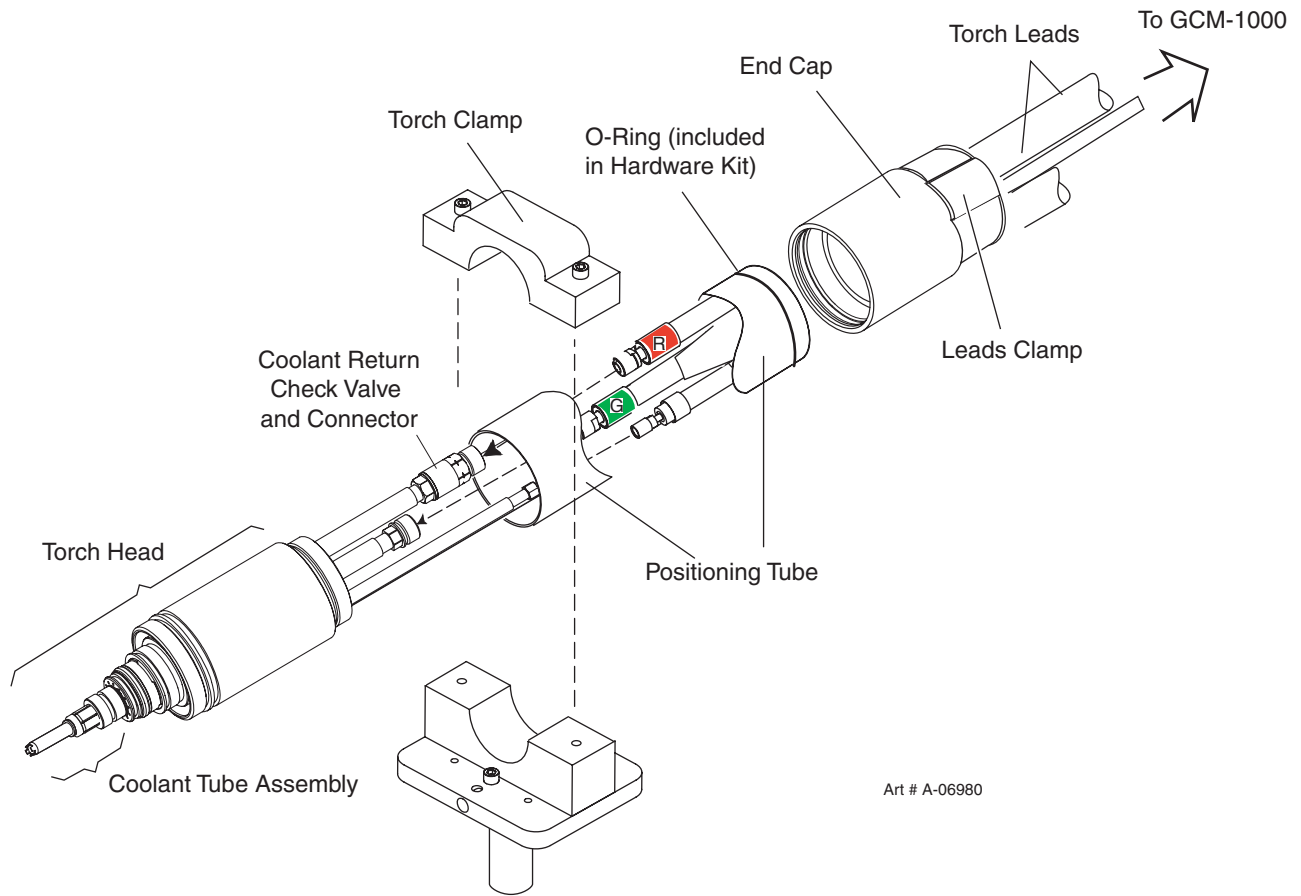

XT-301™ Conventional Plasma Torch Auto-Cut™ 55-100 Amps

Art # A-07806



	Amps	Plasma/Shield Gas	Shield Cup	Shield Cap	Shield Gas Distributor	Tip	Plasma Gas Distributor	Electrode	Cartridge
Mild Steel	55A	Air Plasma / Air Shield	35-1016	35-1025	35-1272	35-1051	35-1041	35-1069	35-1020
		O2 Plasma / Air Shield	35-1016	35-1025	35-1272	35-1051	35-1041	35-1069	35-1020
	100A	Air Plasma / Air Shield	35-1016	35-1027	35-1272	35-1053	35-1041	35-1071	35-1020
		O2 Plasma / Air Shield	35-1016	35-1027	35-1272	35-1053	35-1041	35-1071	35-1020

Stainless Steel Aluminum	55A	Air Plasma / Air Shield	35-1016	35-1034	35-1272	35-1060	35-1041	35-1078	35-1020
		Air Plasma / Air Shield	35-1016	35-1027	35-1272	35-1053	35-1041	35-1071	35-1020
	100A	N2 Plasma / H2O Shield	35-1016	35-1034	35-1272	35-1053	35-1041	35-1089	35-1020
		H35 Plasma / N2 Shield	35-1016	35-1034	35-1272	35-1062	35-1041	35-1080	35-1020

XT-301™ Conventional Plasma Torch Auto-Cut™ 200-300 Amps

Auto-Cut™ 200
Auto-Cut™ 300

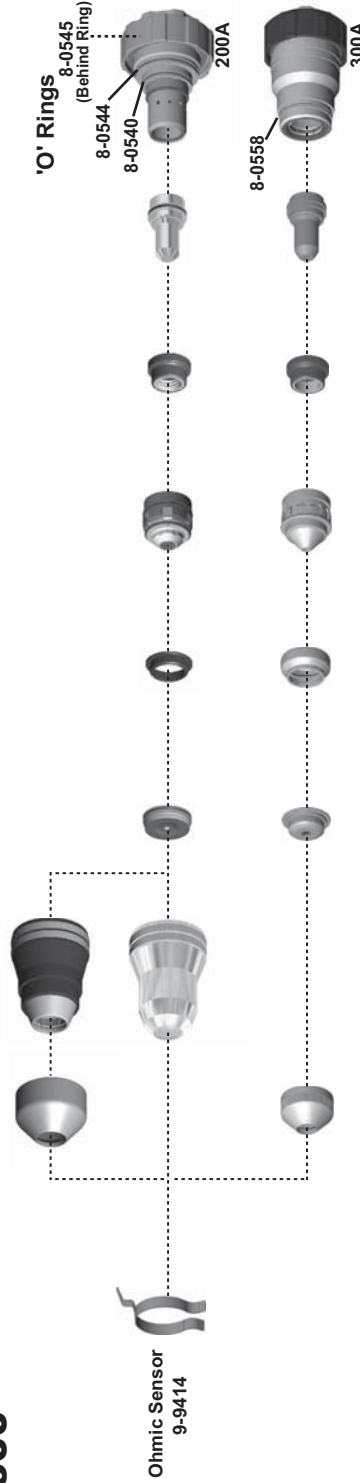

Art # A-07807

Amps	Plasma/Shield Gas	Shield Retainer	Shield Cup	Shield Cap	Shield Gas Distributor	Tip	Plasma Gas Distributor	Electrode	Cartridge
Mild Steel	O2 Plasma / Air Shield	35-1019	35-1018	35-1029	35-1281	35-1056	35-1041	35-1086	35-1020
	Air Plasma / Air Shield	35-1019	35-1018	35-1028	35-1280	35-1055	35-1041	35-1085	35-1020
300A	Air Plasma / Air Shield	35-1021	35-1017	35-1037	35-1283	35-1050	35-1044	35-1088	35-1022
Stainless Steel Aluminum	Air Plasma / Air Shield	35-1019	35-1018	35-1030	35-1282	35-1055	35-1041	35-1085	35-1020
	H35 Plasma / N2 Shield	—	35-1016	35-1031 (≤ 1" (25mm)) 35-1032 (> 1" (25mm))	35-1273	35-1058	35-1043	35-1087	35-1020

Consumables O-Ring Locations and Catalog Numbers

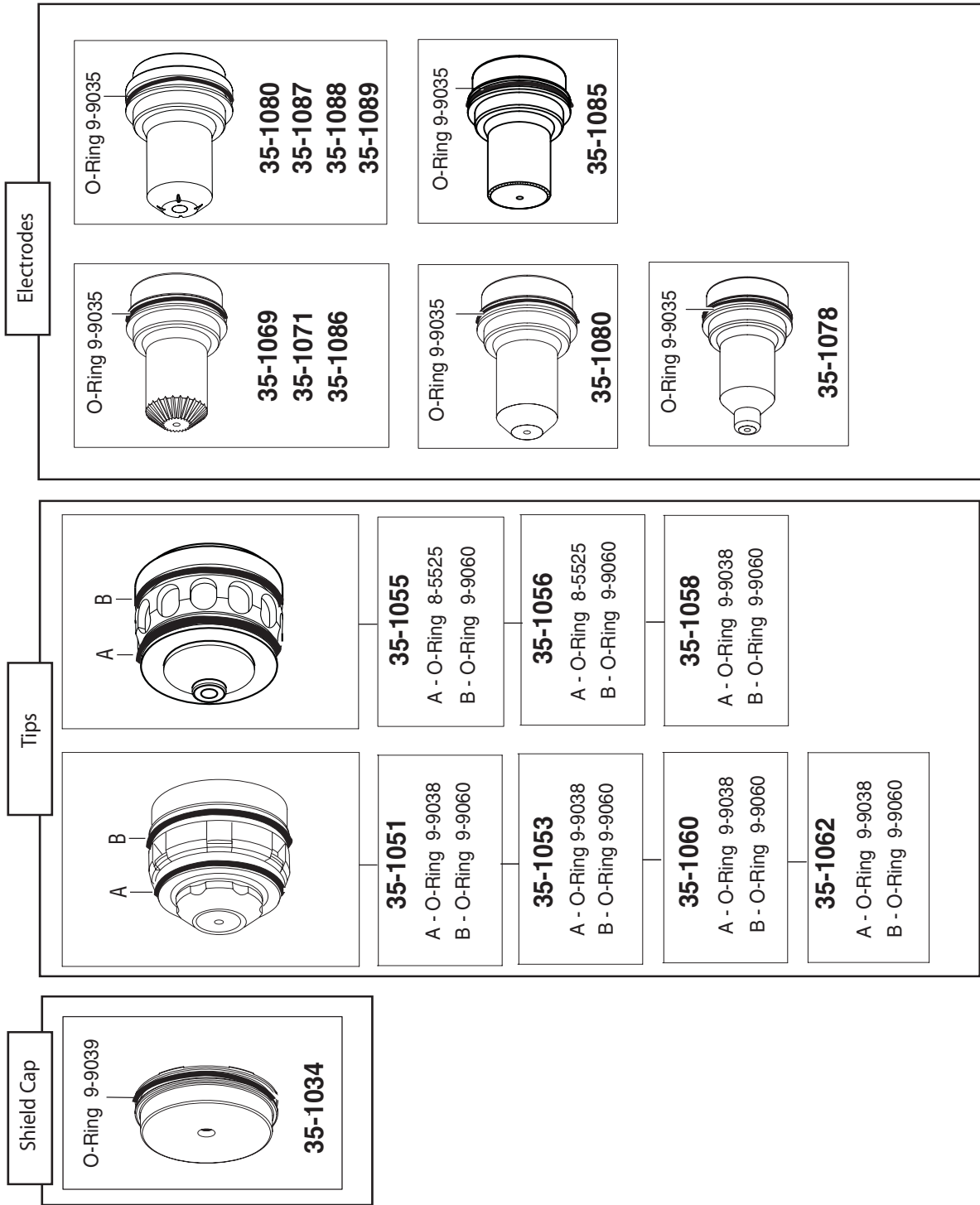

Art # A-07250

PATENT INFORMATION

XT™-301 Plasma Cutting Torch Patents

The following parts are covered under U.S. and Foreign Patents as follows:

Catalog #	Description	Patent(s)
35-1020	Cartridge	US Pat No(s) 6946616; 6919526; 6989505 Other Pat(s) Pending
35-1022	Cartridge	US Pat No(s) 6946616; 6919526; 6989505 Other Pat(s) Pending
35-1068	Electrode	US Pat No(s) 6946616; 6919526; 6989505; 6998566; D517577 Other Pat(s) Pending
35-1069	Electrode	US Pat No(s) 6946616; 6919526; 6989505; 6998566; D517576 Other Pat(s) Pending
35-1070	Electrode	US Pat No(s) 6946616; 6919526; 6989505; 6998566; D517576 Other Pat(s) Pending
35-1071	Electrode	US Pat No(s) 6946616; 6919526; 6989505; 6998566; D517576 Other Pat(s) Pending
35-1072	Electrode	US Pat No(s) 6946616; 6919526; 6989505; 6998566; D517576 Other Pat(s) Pending
35-1077	Electrode	US Pat No(s) 6946616; 6919526; 6989505; 6998566 Other Pat(s) Pending
35-1078	Electrode	US Pat No(s) 6946616; 6919526; D505963; 6989505; 6998566 Other Pat(s) Pending
35-1079	Electrode	US Pat No(s) 6946616; 6919526; 6989505; 6998566 Other Pat(s) Pending
35-1080	Electrode	US Pat No(s) 6946616; 6919526; 6989505; 6998566; D517577 Other Pat(s) Pending
35-1085	Electrode	US Pat No(s) 6946616; 6919526; 6989505; 6998566 Other Pat(s) Pending
35-1086	Electrode	US Pat No(s) 6946616; 6919526; 6989505; 6998566; D517576 Other Pat(s) Pending
35-1087	Electrode	US Pat No(s) 6946616; 6919526; 6989505; 6998566; D517577 Other Pat(s) Pending
35-1088	Electrode	US Pat No(s) 6946616; 6919526; 6989505; 6998566; D517576 Other Pat(s) Pending
35-1040	Plasma Gas Distributor	US Pat No(s) 6946616; 6919526; 6989505 Other Pat(s) Pending
35-1041	Plasma Gas Distributor	US Pat No(s) 6946616; 6919526; 6989505 Other Pat(s) Pending
35-1043	Plasma Gas Distributor	US Pat No(s) 6946616; 6919526; 6989505 Other Pat(s) Pending
35-1044	Plasma Gas Distributor	US Pat No(s) 6946616; 6919526; 6989505 Other Pat(s) Pending
35-1046	Plasma Gas Distributor	US Pat No(s) 6946616; 6919526; 6989505 Other Pat(s) Pending
35-1024	Shield Cap	US Pat No(s) 6946616; 6919526; 6989505 Other Pat(s) Pending
35-1025	Shield Cap	US Pat No(s) 6946616; 6919526; 6989505 Other Pat(s) Pending
35-1026	Shield Cap	US Pat No(s) 6946616; 6919526; 6989505 Other Pat(s) Pending
35-1027	Shield Cap	US Pat No(s) 6946616; 6919526; 6989505 Other Pat(s) Pending
35-1034	Shield Cap	US Pat No(s) 6946616; 6919526; 6989505 Other Pat(s) Pending
35-1028	Shield Cap	US Pat No(s) 6946616; 6919526; 6989505 Other Pat(s) Pending
35-1029	Shield Cap	US Pat No(s) 6946616; 6919526; 6989505 Other Pat(s) Pending
35-1030	Shield Cap	US Pat No(s) 6946616; 6919526; 6989505 Other Pat(s) Pending
35-1031	Shield Cap	US Pat No(s) 6946616; 6919526; 6989505 Other Pat(s) Pending
35-1032	Shield Cap	US Pat No(s) 6946616; 6919526; 6989505 Other Pat(s) Pending
35-1033	Shield Cap	US Pat No(s) 6946616; 6919526; 6989505 Other Pat(s) Pending
35-1035	Shield Cap	US Pat No(s) 6946616; 6919526; 6989505 Other Pat(s) Pending
35-1036	Shield Cap	US Pat No(s) 6946616; 6919526; 6989505 Other Pat(s) Pending
35-1037	Shield Cap	US Pat No(s) 6946616; 6919526; 6989505 Other Pat(s) Pending
35-1039	Shield Cap	US Pat No(s) 6946616; 6919526; 6989505 Other Pat(s) Pending
35-1275	Shield Cap	US Pat No(s) 6946616; 6919526; 6989505 Other Pat(s) Pending
35-1016	Shield Cup	US Pat No(s) 6946616; 6919526; 6989505 Other Pat(s) Pending
35-1018	Shield Cup	US Pat No(s) 6946616; 6919526; 6989505 Other Pat(s) Pending
35-1082	Shield Gas Distributor	US Pat No(s) 6946616; 6919526; 6989505 Other Pat(s) Pending
35-1272	Shield Gas Distributor	US Pat No(s) 6946616; 6919526; 6989505 Other Pat(s) Pending
35-1273	Shield Gas Distributor	US Pat No(s) 6946616; 6919526; 6989505 Other Pat(s) Pending
35-1274	Shield Gas Distributor	US Pat No(s) 6946616; 6919526; 6989505 Other Pat(s) Pending
35-1280	Shield Gas Distributor	US Pat No(s) 6946616; 6919526; 6989505 Other Pat(s) Pending
35-1281	Shield Gas Distributor	US Pat No(s) 6946616; 6919526; 6989505 Other Pat(s) Pending
35-1282	Shield Gas Distributor	US Pat No(s) 6946616; 6919526; 6989505 Other Pat(s) Pending
35-1283	Shield Gas Distributor	US Pat No(s) 6946616; 6919526; 6989505 Other Pat(s) Pending
35-1019	Shield Retainer	US Pat No(s) 6946616; 6919526; 6989505 Other Pat(s) Pending
35-1021	Shield Retainer	US Pat No(s) 6946616; 6919526; 6989505 Other Pat(s) Pending
35-1050	Tip	US Pat No(s) 6946616; 6919526; 6989505; 7005600; D519135; D524,336 Other Pat(s) Pending
35-1051	Tip	US Pat No(s) 6946616; 6919526; 6989505; 7005600; D519135; D524,336 Other Pat(s) Pending
35-1052	Tip	US Pat No(s) 6946616; 6919526; 6989505; 7005600; D519135; D524,336 Other Pat(s) Pending

XT™-301 Plasma Cutting Torch Patents

The following parts are covered under U.S. and Foreign Patents as follows:

Catalog #	Description	Patent(s)
35-1053	Tip	US Pat No(s) 6946616; 6919526; 6989505; 7005600; D519135; D524,336 Other Pat(s) Pending
35-1054	Tip	US Pat No(s) 6946616; 6919526; 6989505; 7005600; D519135; D524,336 Other Pat(s) Pending
35-1055	Tip	US Pat No(s) 6946616; 6919526; 6989505; 7005600 Other Pat(s) Pending
35-1056	Tip	US Pat No(s) 6946616; 6919526; 6989505; 7005600 Other Pat(s) Pending
35-1057	Tip	US Pat No(s) 6946616; 6919526; 6989505; 7005600 Other Pat(s) Pending
35-1058	Tip	US Pat No(s) 6946616; 6919526; 6989505; 7005600; D519135; D524,336 Other Pat(s) Pending
35-1060	Tip	US Pat No(s) 6946616; 6919526; 6989505; 7005600; Other Pat(s) Pending
35-1061	Tip	US Pat No(s) 6946616; 6919526; 6989505; 7005600; D519135; D524,336 Other Pat(s) Pending
35-1062	Tip	US Pat No(s) 6946616; 6919526; 6989505; 7005600; D519135; D524,336 Other Pat(s) Pending
35-1064	Tip	US Pat No(s) 6946616; 6919526; 6989505; 7005600 Other Pat(s) Pending
35-1001	Torch Head	US Pat No(s) 6946616; 6919526; 6852944; 6989505; 7071443 Other Pat(s) Pending

The following parts are licensed under U.S. Patent No. 5,120,930 and 5,132,512:

Catalog #	Description
35-1027	Shield Cap
35-1028	Shield Cap
35-1029	Shield Cap
35-1030	Shield Cap
35-1032	Shield Cap

NOTE

This manual may refer to some or all of the parts listed.