



 **KALIBURN**
PLASMA CUTTING INNOVATION

New heights in torch control.

 **INOVA**TM

Now there's no question about who's in control.

Introducing the INOVA™ torch height control by KALIBURN.

With it, you can program more functions, set tighter parameters and get better resolution. INOVA reduces cycle time and gives you a more accurate cut. It is the most versatile torch height control yet. And you can use it on any plasma cutting system—even one you already own.

INOVA IS PRECISELY WHAT YOU NEED.



We've added a microcontroller with 35 programmable functions and interfacing for 8 torch stations. Program as few as 3 functions and you're up and running. You get precision and stability for all plasma cutting, including high definition applications. It has a state-of-the-art anti-collision system to protect the torch, and an optional remote control with touchscreen to give you greater flexibility.

EASIER PROGRAMMING.

The touchscreen remote is easier to program and more versatile than a pendant. You can even take it a step further and program all INOVA functions from a PC-based CNC controller.

MAINTAINS SET ARC VOLTAGE BETTER.

INOVA uses a software digital signal processing servo loop, so you maintain the selected arc voltage with the highest degree of accuracy — +/- 0.4 volts! Precise arc voltage control affects dross formation, cut face appearance and the dimensional consistency of the part. Achieve a more exact cut with INOVA's stable platform, precision ball screw and guide rails and preloaded guide bearings.

FINER RESOLUTION.

INOVA gives you a position control with an encoder resolution to 0.0001 inch, and an arc voltage setting resolution to 0.1 volt. This precise setting gives you unparalleled control over your cut, with the smallest cut angle, kerf width and face variation.



EASY TO PROGRAM.

A MICROPROCESSOR PROVIDES MORE PROGRAMMABLE FUNCTIONS:

- arc voltage from 50 to 250 volts in .1 volt increments
- manual travel speed
- plate sense speed during initial pierce height setting (IHS)
- adjustable plate touch force during IHS (touch force method is used as a backup to soft-touch ohmic contact method)
- initial pierce height
- cutting height (torch moves to the cutting height after the pierce time is complete but before the AVC mode is activated)
- pierce time (time before torch moves to the cutting height)
- partial raise height (retract distance from the last cutting height)
- torch retract delay
- corner AVC disable (prevents torch diving during corners)
- AVC delay (delay time from the removal of a corner AVC disable signal and the resumption of arc voltage control)
- high to low speed crossover point during IHS
- cycle complete signal
- plasma gas preflow during IHS-on/off
- clear-the-plate-on/off
- arc voltage limiter-on/off
- automatic collision avoidance-on/off
- adjustable gain
- IHS test/run (test the initial pierce height without starting the plasma torch)

INOVA OFFERS THESE OTHER FEATURES FOR BETTER CUTS:

- up to 8 torch stations
- collision protection system with auto height correction
- maximum retraction speed—600 ipm
- optional remote control with touch screen interface
- RS-422 communication link
- software servo control loop
- XY partial raise enable/disable for long distance traverses—returns torch to upper limit switch

CONTROL CONSOLE

Input power	115 VAC 60Hz./230 VAC 50Hz.	
Input current	3 amps/1.5 amps	
Height	6.35 in.	161 mm.
Width	15.5 in.	394 mm.
Depth	12 in.	305 mm.
Weight	30 lbs.	13.6 kg.
Arc voltage range	50-250 VDC	
Control accuracy	± 0.4 VDC	

POSITIONER

Positioning speed—HD model	500 ipm.	12.7 m/min.
Positioning speed—S model	600 ipm.	15.2 m/min.
Height	27.5 in.	699 mm.
Width	4.4 in.	112 mm.
Weight	15 lbs.	6.8 kg.
Maximum stroke	9.2 in.	234 mm.
Lifting capacity—HD model	50 lbs.	23 kg.
Lifting capacity—S model	25 lbs.	11 kg.

FEATURES

ARC VOLTAGE CONTROL

- DSP servo system is the most advanced voltage control available
- Responds at speeds up to 600 ipm
- Rapid response means arc voltage control available for high, intermediate or low-speed plasma arc cutting
- Settings in 0.1 volt increments

INITIAL HEIGHT POSITIONING

- patented plate sensing technique requires no external switches or devices
- soft-touch ohmic contact plate sensing works on all plate thicknesses
- manual positioning if automatic initial height positioning is not desired

PROGRAMMABLE PARTIAL RAISE

- Allows retraction distance to be set between 0" and full raise
- Improves cycle time and output

GAS PREFLOW

- Starts simultaneously with initial torch height positioning
- Saves several seconds on each cut, allowing more cut pieces per hour

ARC VOLTAGE CONTROL LIMITER

- Prevents torch damage during kerf crossing

CORNER

- Allows the arc voltage control to be disabled while cutting
- Prevents the torch from diving into the workpiece during corners or when initially piercing heavy plate

CYCLE COMPLETE SIGNAL

- Minimizes cycle time by alerting the machine controller that the plasma torch has been fully retracted

RETRACTION DELAY

- Selectable delay time allows current slope-down to occur prior to retracting torch, extending electrode life

INOVA™

A CABLE SET LISTED BELOW AND TORCH CLAMP ARE ALL THAT ARE NEEDED TO COMPLETE THE BASIC SYSTEM.

- Cable "A" console to remote
- Cable "B" console to positioner
- Cable "C" console to plasma power supply
- Cable "D" console to voltage divider
- Cable "E" console to work ground
- Cable "F" console to cnc machine

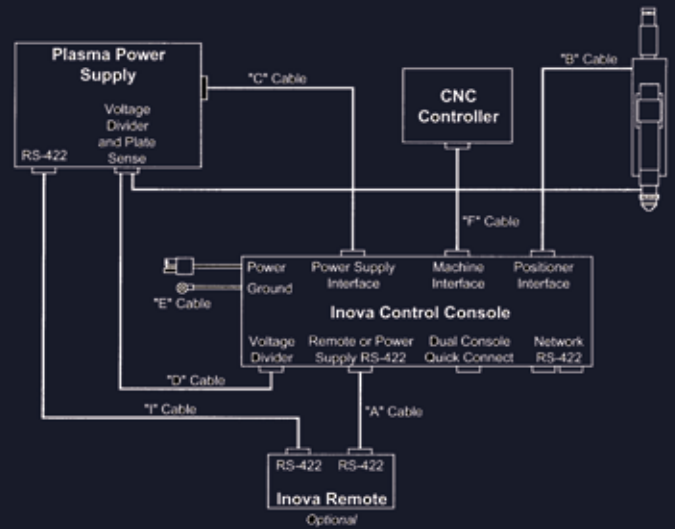
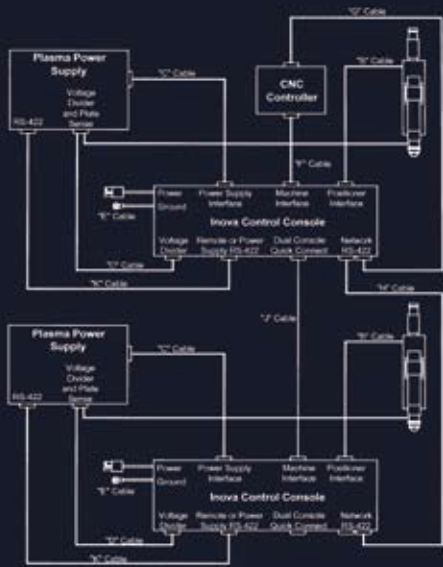

Fewer components make the INOVA simple to install and maintain.

WORKS HARDER AND FASTER.

INOVA gives you high speed for positioning and the highest speeds practical for cutting. You can produce more cut pieces per hour by saving several seconds on each cut with the automatic gas initiator, which allows torch positioning and gas preflow to occur at the same time. Our torch height control positioner weighs pounds less than the others, so it reduces machine loads. Our Z-axis speed is three times faster, at 600 ipm. Reduce cycle time between cuts by reducing torch retraction with the programmable partial raise.

INOVA — THE SMARTEST WAY TO CUT IT.

All of INOVA's features work together to make selecting the INOVA torch height control the best choice. You get a smart machine that gives better cut quality and saves you time and effort. Fewer components make INOVA easier to install and maintain than other torch height controls, too. So whether you're ordering a new system or upgrading your current one, ask for INOVA by KALIBURN.



455 Fleming Road ■ Charleston, SC 29412 ■ (843) 795-4286 ■ (800) 252-2850
 Fax (843) 795-8931 ■ www.kaliburn.net ■ e-mail: info@kaliburn.net