

*Mini*  
**HORNET**   
**4x4**

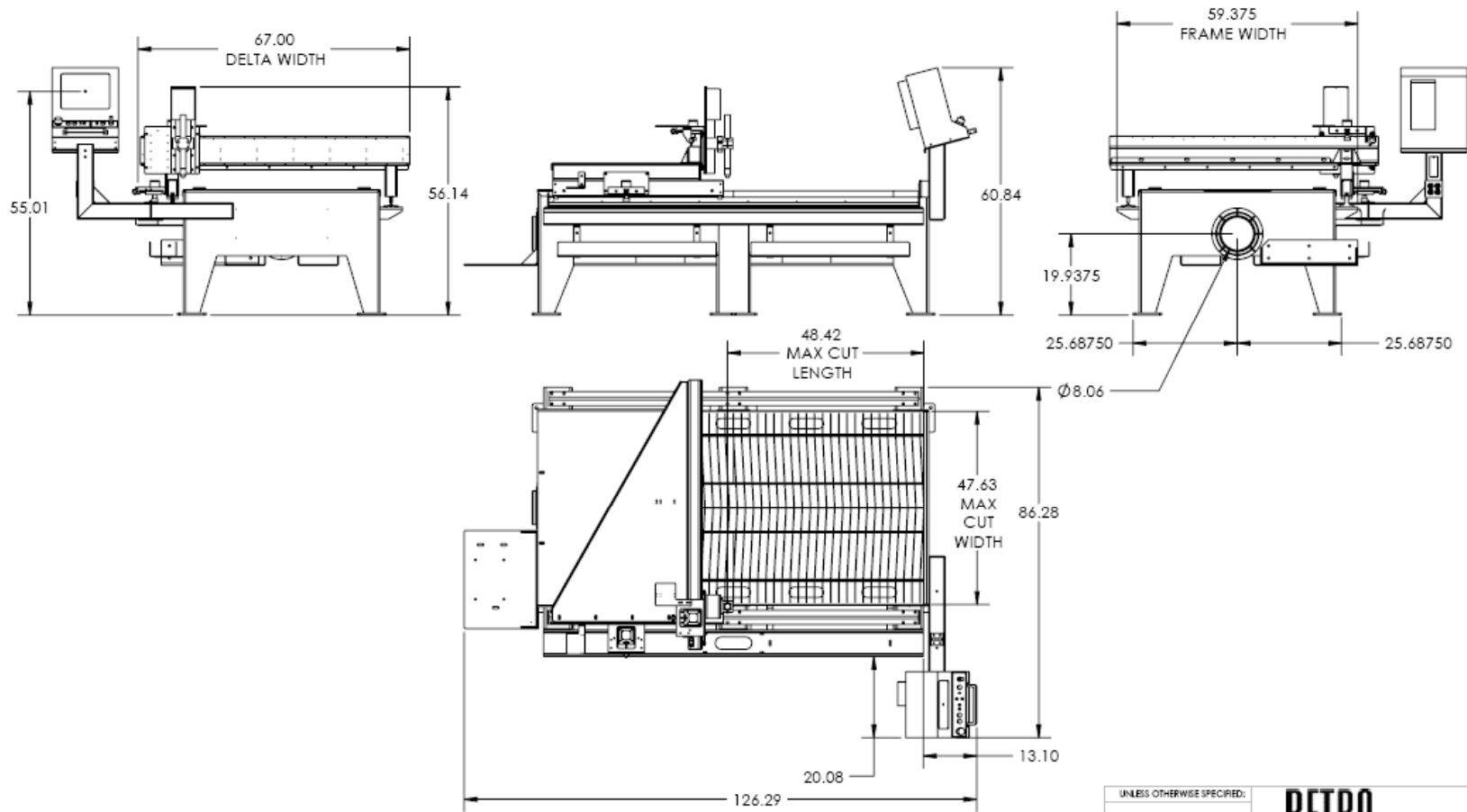



MATERIAL:  
PART NUMBER:

UNLESS OTHERWISE SPECIFIED:		
DIMENSIONS ARE IN INCHES		
TOLERANCES:		
FRACTIONAL ±		
ANGULAR: EACH ±		
TWO PLACE DECIMAL ± .005		
THREE PLACE DECIMAL ± .005		
INTERPRET GEOMETRIC TOLERANCING PER:		
MATERIAL:		
STOCKSIZE:		
DO NOT SCALE DRAWING		
<b>RETRO SYSTEMS</b>		
TITLE:		
ASSY,MATC_MINI		
SIZE		
B DWG. NO.		
ASSY,MATC_MINI_GEN DIM		
SCALE: 1:32/WEIGHT: 1670.86 SHEET 1 OF 1		

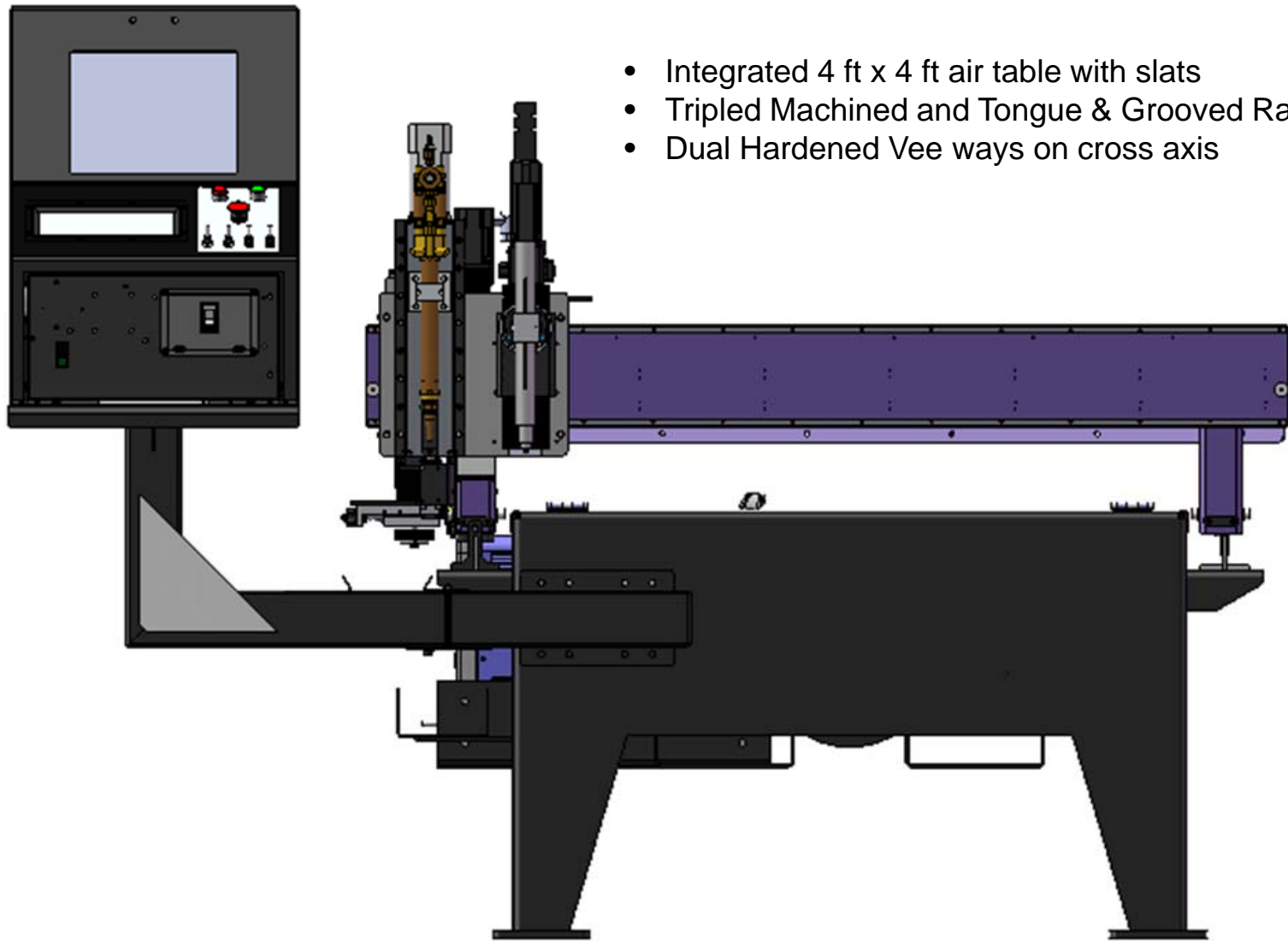

- Integrated 4 ft x 4 ft air table with slats
- Tripled Machined and Tongue & Grooved Rails
- Dual Hardened Vee ways on cross axis

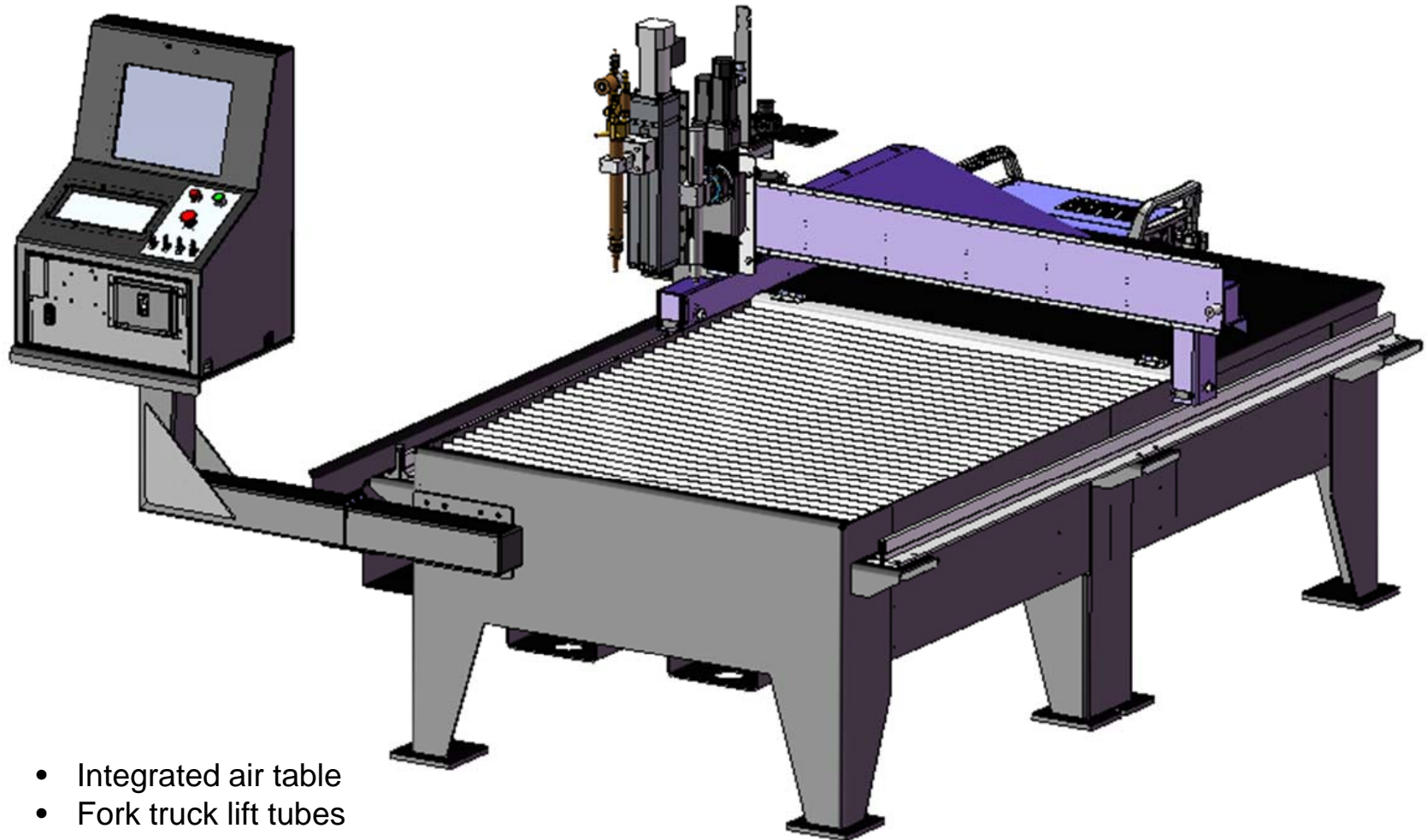

- Integrated air table
- Fork truck lift tubes
- Leveling bolts at each corner

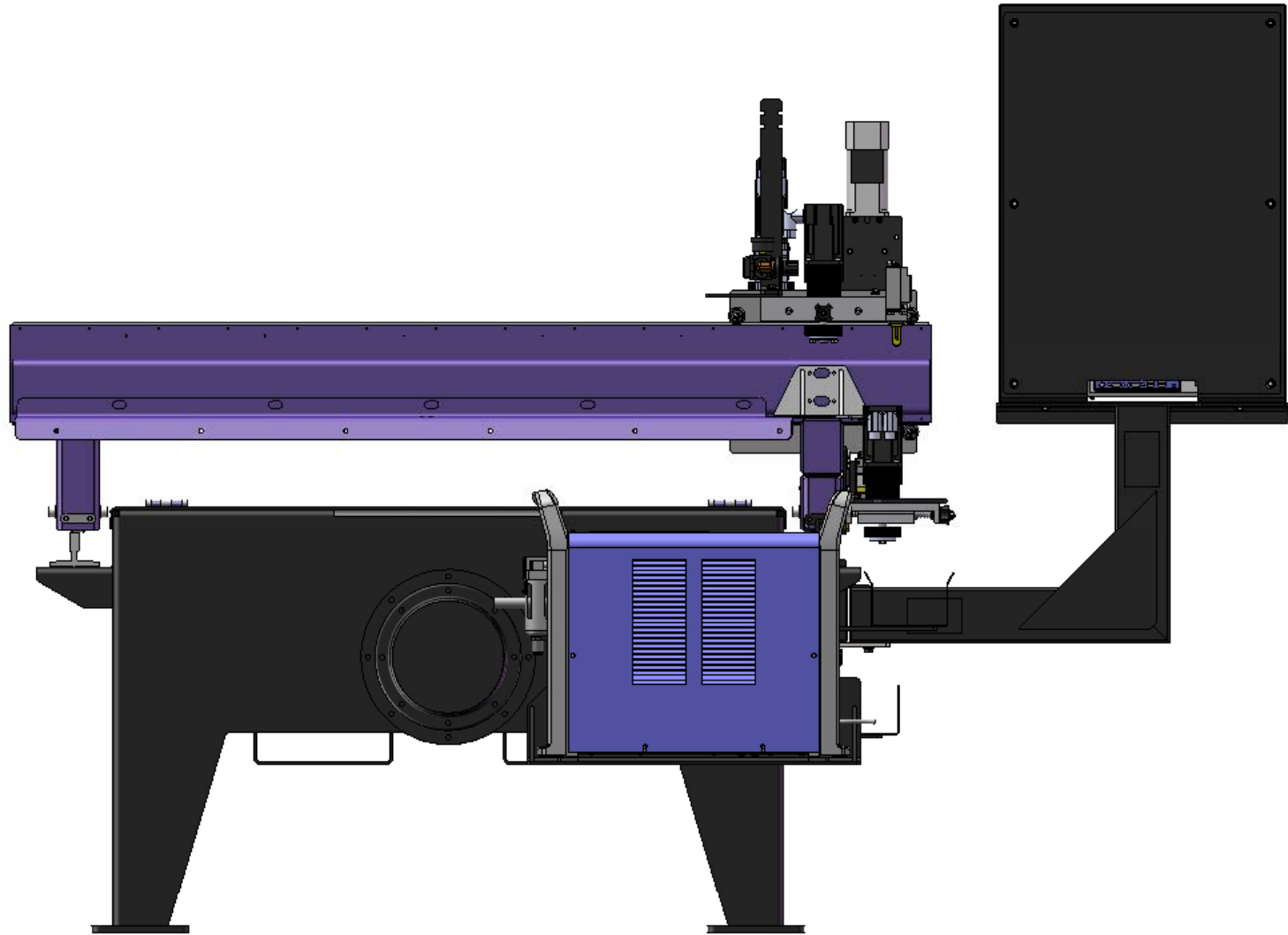

10" Air exhaust flange and plasma power supply mounting

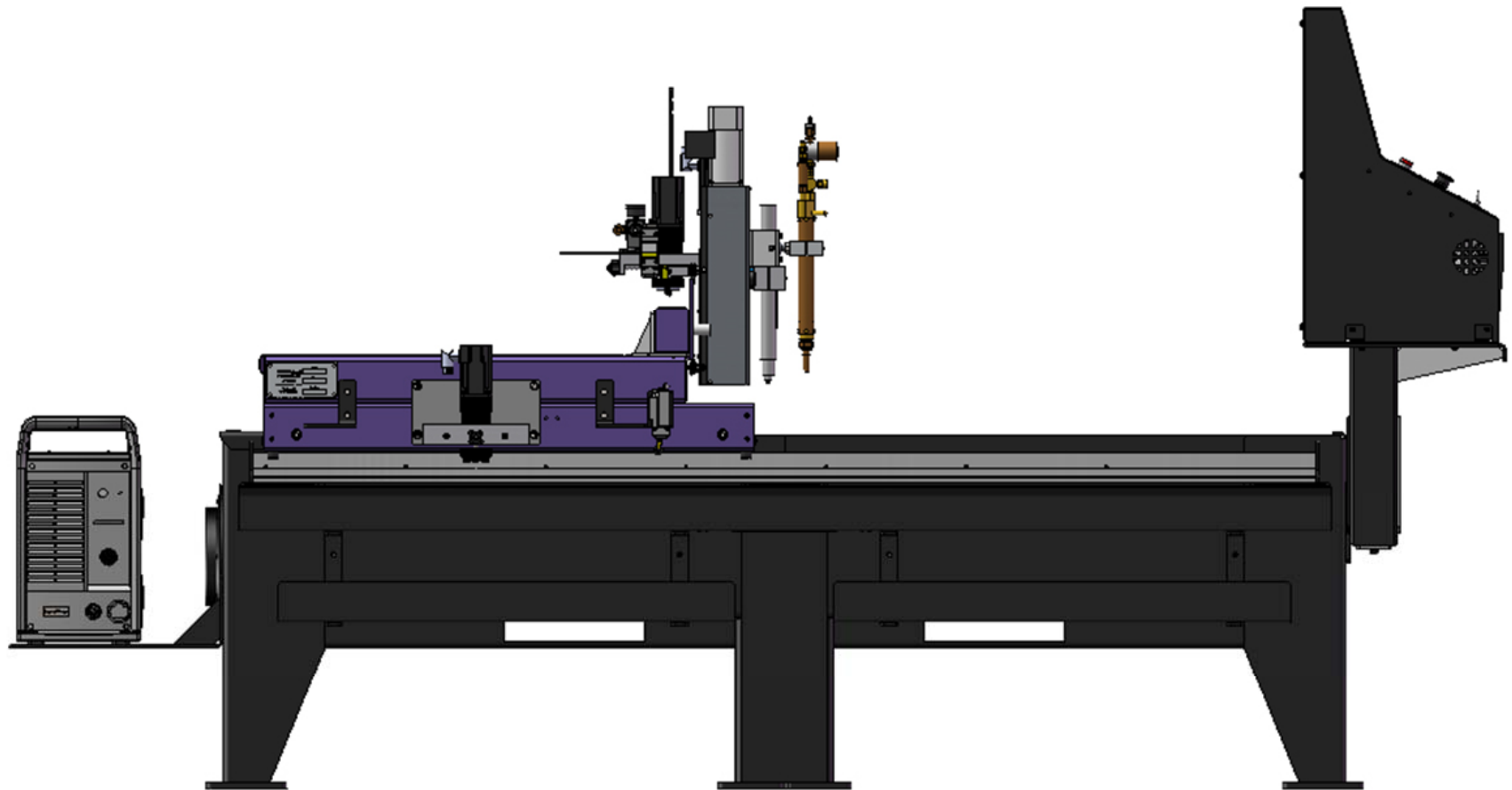

- Flexible cable carriers in support trays
- Elevated cable ways
- Triple Machined and Tongue & Grooved Rail
- Heavy duty gear rack

- AC Servo motors (600 watt)
- Planetary gear heads (5 arc minute)
- Machined motor mounts
- Homing limit switches

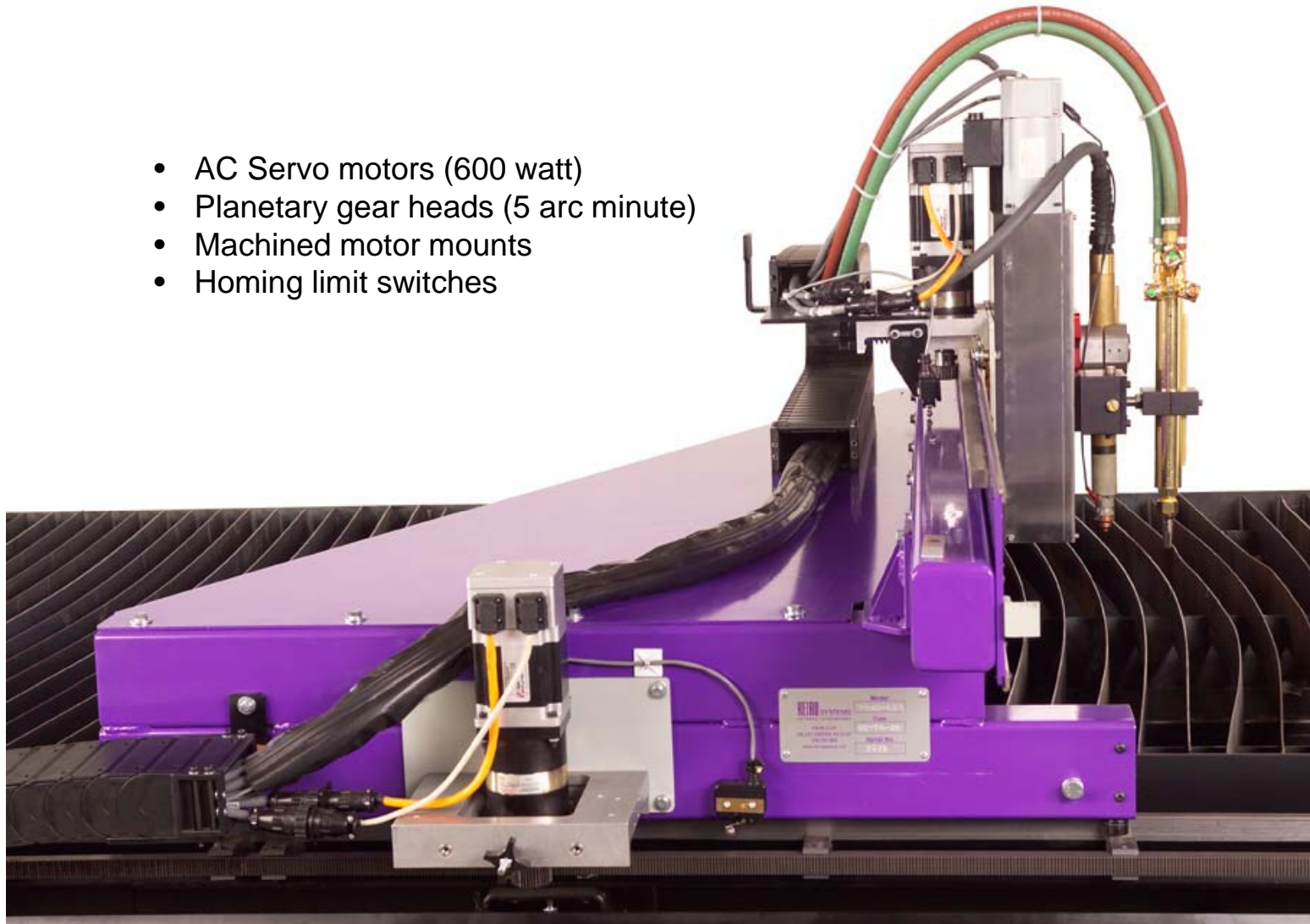

Master rail and view of back deck

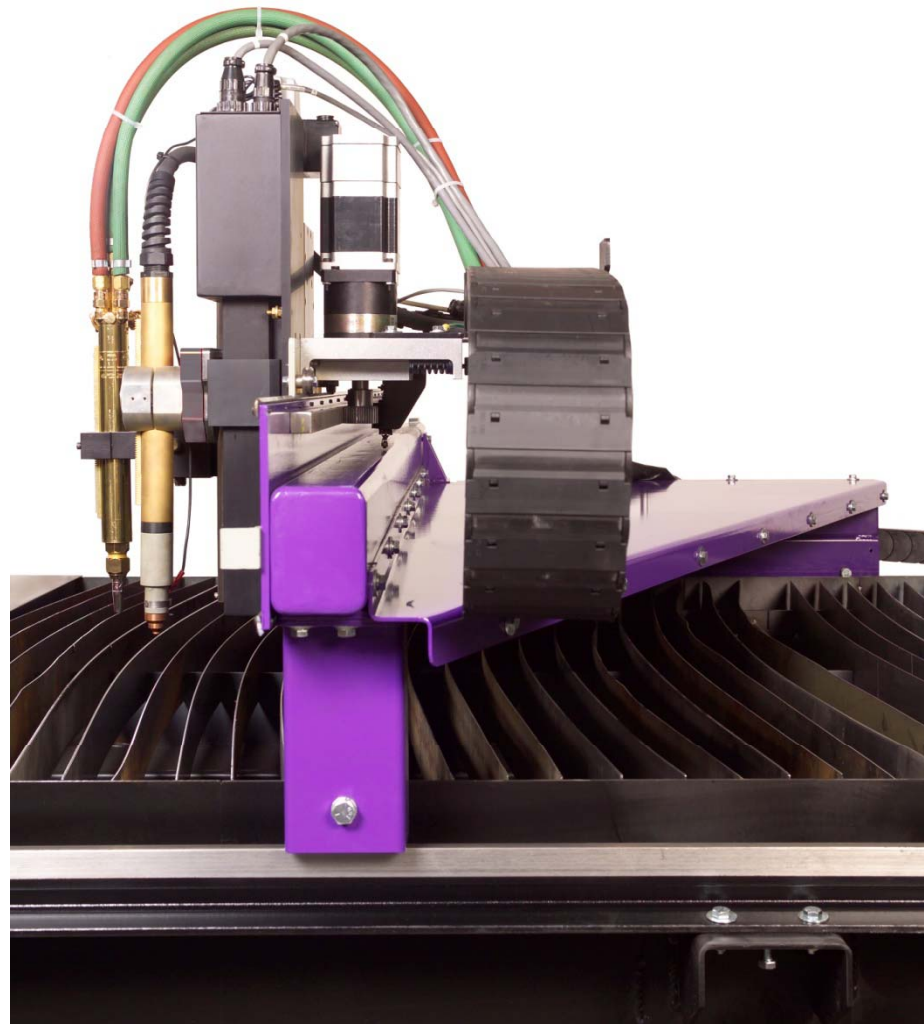

Outboard rail and view of back deck



- Hypertherm MicroEDGE™ CNC Control
- Industrial PC enclosure
- 15" TOUCH Screen
- Flush Mounted Industrial Keyboard
- Floppy Drive, CD ROM Drive, (5) USB Ports
- RJ45 Network Port
- CNC ON/OFF switch
- E-STOP
- Dust Collector START/STOP buttons (optional)
- Plasma P.S. ON/OFF Switch
- Plasma Torch UP/DOWN Switch
- Plasma/Ox-fuel Mode Switch (optional)

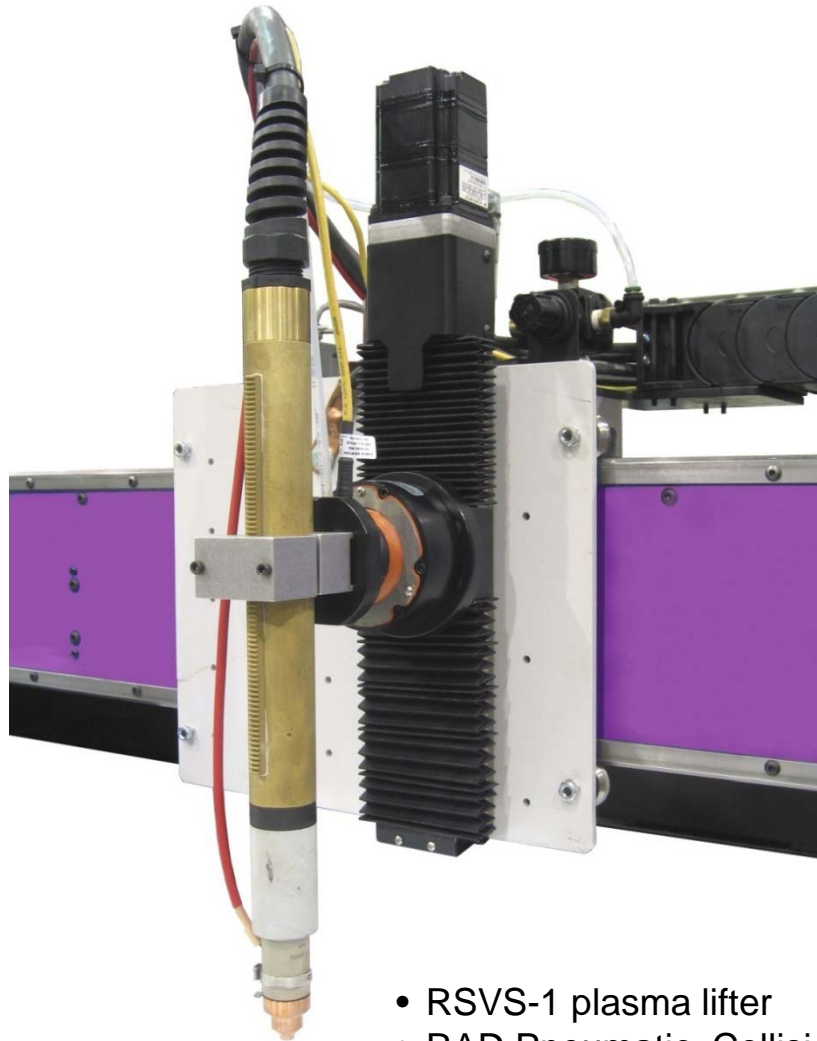

- RSVS-1 plasma lifter
- RAD Pneumatic Collision Mount
- Oxy-fuel lifter (not pictured)

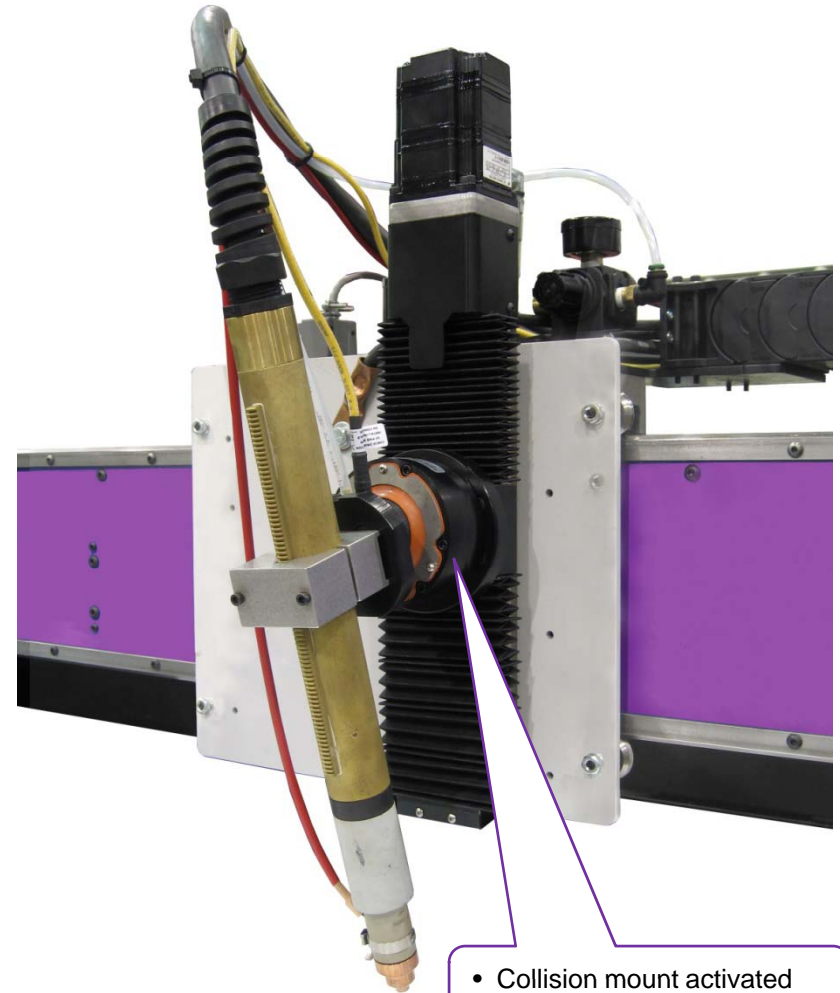

- Collision mount activated
- Mount resets after collision

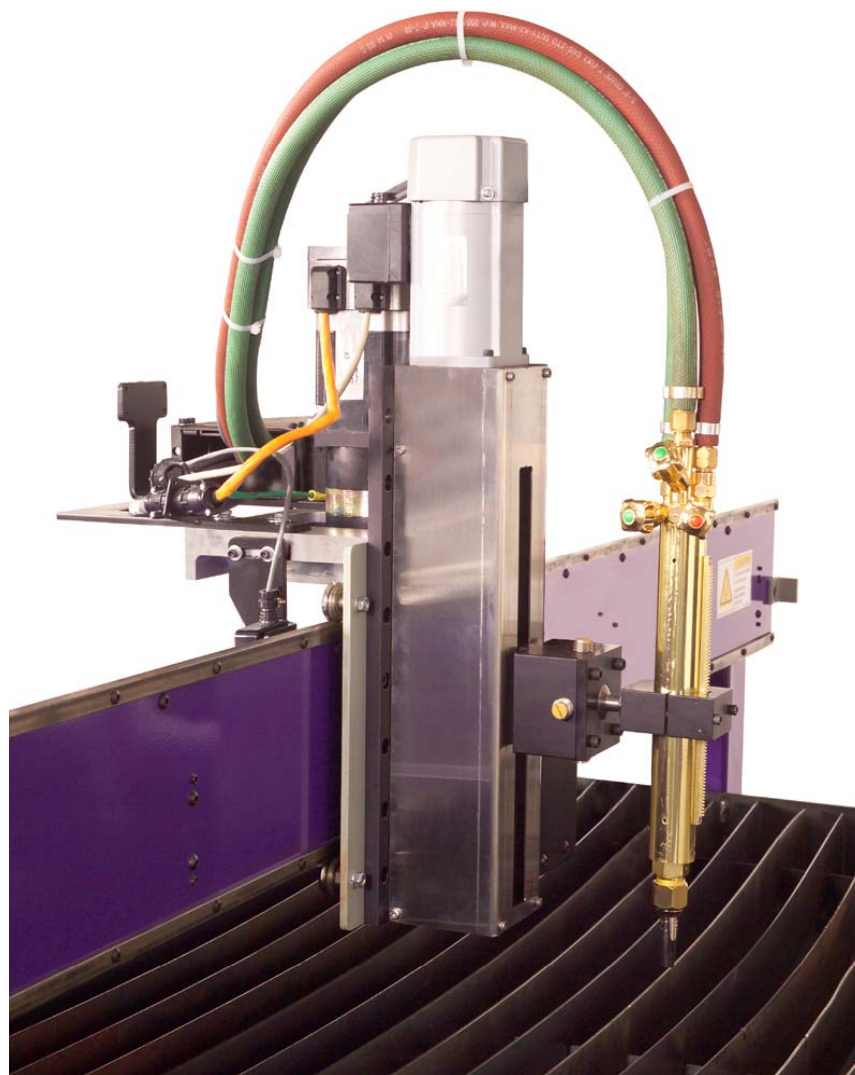

- Oxyfuel lifter and Victor MT310 torch



Center  
Exhaust Tube  
runs length of  
table to  
improve  
smoke  
removal

Air table with salts removed to show **Center Exhaust Tube**

Thank you