

RETRO SYSTEMS

Multi Zoned Center Draft Air Table

Description:

- 1/4" thick steel outer construction
- Center exhaust tube with air cylinder controlled dampers
- Zones 3-5 ft long X width of table
- Zones activated based on machine location along rails
- Slats included on 2" - 4" centers
- Removable slag trays – **optional**
- Dust collection system - **optional**

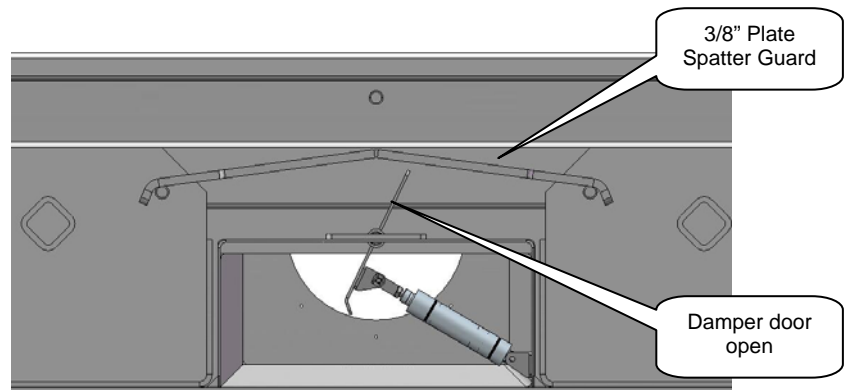

End view of air table showing exhaust tunnel and air cylinder activated damper door in the open position.

NOTE TO CUSTOMERS PROVIDING EXHAUST SYSTEMS:

- Approximately 4,000 CFM @ 6 inches static pressure recommended

Application:

- Reduction of smoke from cutting process

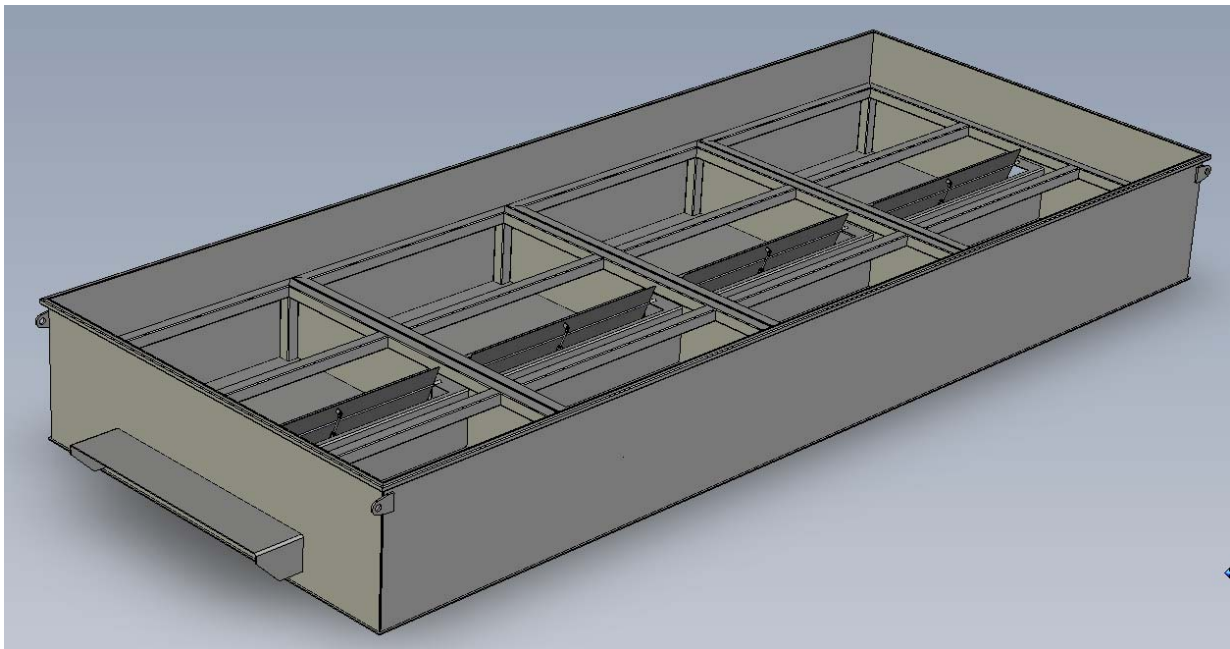

Four Zones of Air Table - Slag Trays removed to expose center air tube and air cylinder activated dampers